

**Sensepoint XCD RFD
(Remote Flammable Detector)**

1 Safety

Ensure that this Operating Manual is read and understood BEFORE installing / operating / maintaining the equipment. Pay particular attention to Warnings and Cautions. All document Warnings are listed here and repeated where appropriate at the start of the relevant chapter(s) of this Operating Manual. Cautions appear in the sections/sub-sections of the document where they apply

WARNINGS

Sensepoint XCD RFD is designed for installation and use in Zone 1 or 2 hazardous areas in many countries including Europe .

Installation must be in accordance with the recognized standards of the appropriate authority in the country concerned.

Access to the interior of the detector, when carrying out any work, must only be conducted by trained personnel.

Before carrying out any work ensure local regulations and site procedures are followed. Appropriate standards must be followed to maintain the overall certification of the detector.

If using an anti-seize compound, the threads should be thinly coated with an approved silicone free compound e.g. petroleum jelly

To reduce the risk of ignition of hazardous atmosphere, de-classify the area or disconnect the equipment from the supply circuit before opening the detector enclosure. Keep assembly tightly closed during operation.

Never attempt to open a junction box/enclosure or replace/refit the sensor in potentially hazardous atmospheres while power is still applied to the transmitter.

The detector must be earthed/grounded for electrical safety and to limit the effects of radio frequency interference. Earth/ground points are provided inside and outside the unit. The internal grounding shall be used as the primary equipment ground. The external terminal is only a supplemental bonding connection where local authorities permit or require such a connection.

Ensure that all screens/instrument earth/clean earth wiring is earthed/grounded at a single point (either at the controller or detector - BUT NOT BOTH) to prevent false readings or alarms that may occur due to potential earth/ground loops.

Take care when handling sensors as they may contain corrosive solutions.

Do not tamper with or in any way disassemble the sensor.

Do not expose to temperatures outside the recommended ranges.

Do not expose sensors under storage conditions to organic solvents or flammable liquids.

Refer to the local or national regulations relative to the installation at the site. For Europe see EN60079-29-2, EN60079-14 and EN61241-14.

Only assessed for ATEX for ignition hazards.

This equipment is designed and constructed as to prevent ignition sources arising, even in the event of frequent disturbances or equipment operating faults. Note: The control card must have a suitably rated fuse.

The sensor head must be fitted with the supplied weather protection, and mounted so that the sinter is pointing downward to provide ingress protection IPX6.

The weather protection is a potential electrostatic charging hazard. The manufacturer's instructions should be observed.

2 Information

This manual is for use with the Sensepoint XCD RFD range transmitters only.

The Start-up/Surge/In rush current is dependant on the type of power supply used. The typical start-up current for Sensepoint XCD RFD is less than 800mA. Measure the start-up current using the specific power supply before installation to ensure suitability for your application.

Honeywell Analytics can take no responsibility for installation and/or use of its equipment if not done so in accordance with the appropriate issue and/or amendment of the Technical Manual.

The reader of this Operating Manual should ensure that it is appropriate in all details for the exact equipment to be installed and/or operated. If in doubt, contact Honeywell Analytics for advice.

The following types of notices are used throughout this Operating Manual:

WARNING

Identifies a hazardous or unsafe practice which could result in severe injury or death to personnel.

Caution: Identifies a hazardous or unsafe practice which could result in minor injury to personnel, or product or property damage.

Note: Identifies useful/additional information.

Every effort has been made to ensure the accuracy of this document; however, Honeywell Analytics can assume no responsibility for any errors or omissions in this document or their consequences.

Honeywell Analytics would greatly appreciate being informed of any errors or omissions that may be found in the content of this document.

For information not covered in this document, or if there is a requirement to send comments/corrections about this document, please contact Honeywell Analytics using the contact details given on the back page.

Honeywell Analytics reserve the right to change or revise the information supplied in this document without notice and without obligation to notify any person or organization of such revision or change. If information is required that does not appear in this document, contact the local distributor/agent or Honeywell Analytics.

3 Table of contents

1 Safety	2
2 Information	3
4 Introduction	6
4.1 Transmitter.....	7
4.2 Flammable Gas sensors.....	7
4.2.1 Sensepoint XCD flammable gas sensors	8
4.2.2 Sensepoint LEL Flammable gas sensors	8
4.3 Accessories.....	9
5 Installation	10
5.1 Mounting and location.....	11
5.2 Mounting the transmitter	11
5.3 Installing the sensor	12
6 Electrical connections	14
6.1 Transmitter Wiring.....	15
6.2 Terminal connections	16
6.3 Power.....	17
6.4 Cabling.....	18
6.5 Cable and Earth/Ground regimes	18
6.6 Ground Terminal Wiring	19
7 Default configuration	20
8 Normal Operation	21
8.1 Display Screen.....	21
8.2 System Status.....	22
8.3 Magnetic Wand Activation.....	23
8.4 Operation Mode Structure	23
9 First time switch on (Commissioning)	24
10 Response Check and Calibration	26
10.1 Zeroing and span calibration	26
11 General Maintenance	30
11.1 Operational Life.....	30
12 Servicing	31
12.1 Sensor replacement.....	31
12.2 Replacing Modules within the Transmitter	33
12.3 Faults and Warnings	34
13 Menu's and Advanced Configuration	35
13.1 Abort Function.....	35
13.2 Configuration Mode	35
13.3 Sensor / Gas Selection	41
13.4 Review Mode	43
14 General specification	46
15 Ordering information	47
16 Warranty statement	49
17 Installation Drawing	50

17.1 Mechanical Installation Drawing	50
17.2 Electronic Connection Drawing.....	51
17.3 Duct Mounting Drawing	52
17.4 Collecting Cone Drawing	53
17.5 Mounting Bolt Assy Drawing	54
17.6 Mounting Bracket Drawing.....	55
17.7 Sensepoint XCD RFD Sensor	56
18 Certification.....	57
18.1 China GB Ex and PA.....	57
18.2 Korea KTL.....	60
18.3 European ATEX	61
18.4 International IEC	63
18.5 Sensepoint XCD ATEX Name Plate	65
18.6 Sensor Cartridges Label	66
19 Cross Interference and Cross Calibration	67
19.1 Cross Calibration Flammable Gas Detector	67
19.2 Meter Multiplication Factors for Sensepoint XCD-IR Propane.....	70

4 Introduction

The Sensepoint XCD RFD (“Exceed RFD”) transmitter allows the user to either directly or remotely mount a flammable gas sensor from the Sensepoint XCD and Sensepoint sensor range. The remote sensor can be located up to 30 meters (100 feet) from the transmitter. The transmitter features a display and three programmable relays for controlling external equipment e.g. alarms, sirens, valves or switches. The transmitter provides an industry standard 3-wire, 4-20mA source or sink output for connection to a dedicated gas detection control system or PLC.

The construction of Sensepoint XCD RFD allows it to be used in hazardous area locations; it may also be used in other areas not classified as hazardous. Sensepoint XCD RFD is suitable for use in Zone 1 or 2 hazardous areas (International).

Calibration and maintenance is carried out using a Magnetic Wand, this allows a single user to undertake routine maintenance without needing to access internal components.

Sensepoint XCD RFD comprises of the main parts as shown below.

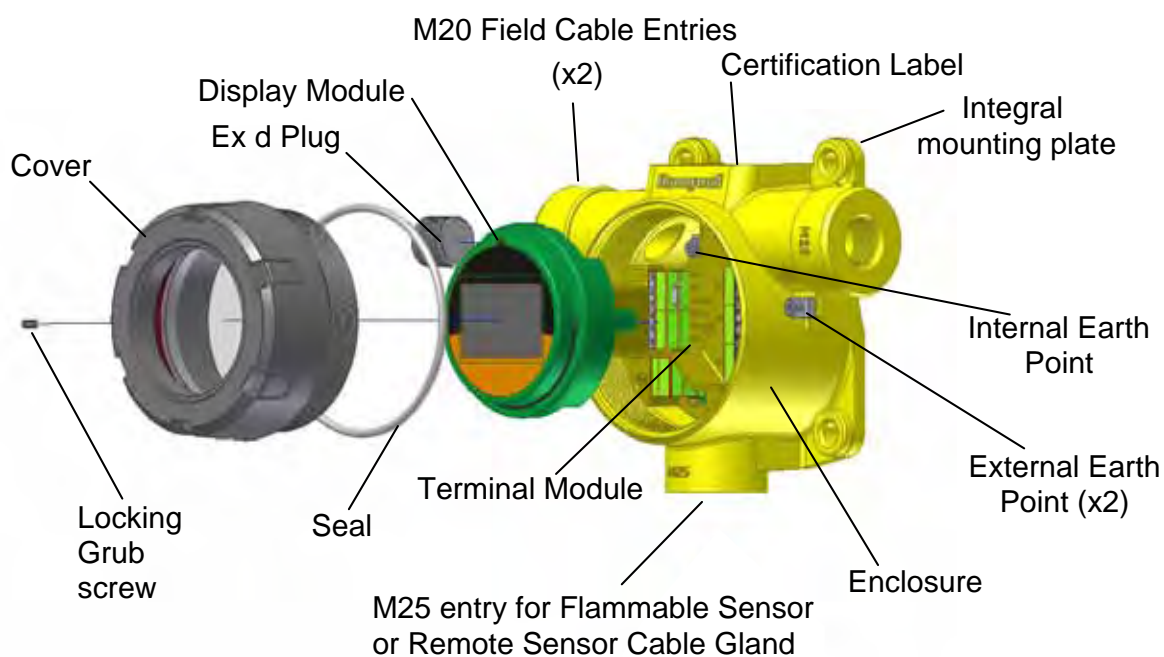

Diagram 1. – Exploded View

4.1 Transmitter

The transmitter enclosure has three threaded entries. The two cable entries either side of the upper part of the transmitter housing are for connecting the power source, signal output and relay contacts to associated signalling equipment. The bottom M25 entry allows local mounting of a Sensepoint XCD RFD or Sensepoint sensor or cable entry when using a remotely mounted sensor.

A local LCD provides gas type, concentration, alarm and operating status. The display provides numerical, bar graph and icon information.

Diagnostic information may also be displayed when the transmitter is interrogated using a magnet. The transmitter cover has a glass window which allows use of the Magnetic Wand to activate the three user interface magnetic switches that are located on the front of the display module. The magnet also enables a non intrusive, one-man calibration and configuration facility for the Sensepoint XCD RFD.

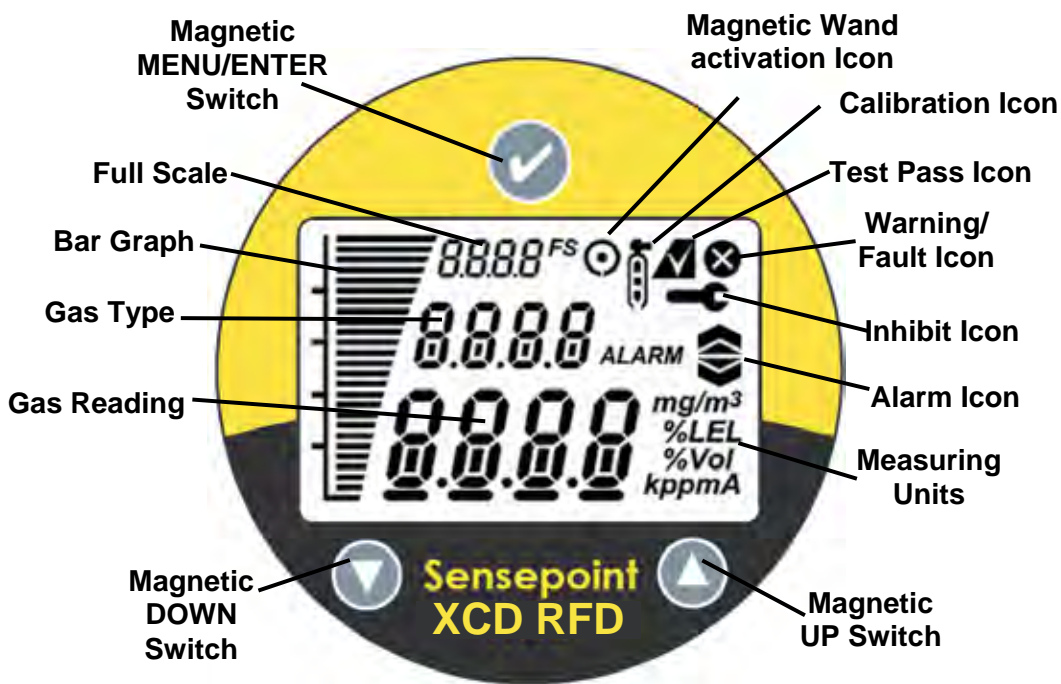

Diagram 2: Sensepoint XCD RFD Display and Magnetic Switches

4.2 Flammable Gas sensors

Sensepoint XCD RFD is designed to work with the flammable sensors from the Sensepoint XCD and Sensepoint sensor ranges. Sensepoint XCD sensors use NDIR infrared and electro-catalytic technologies. The Sensepoint XCD range is ATEX approved for use throughout Europe and many parts of the world.

Please refer to chapter 15 'Ordering information' for more detail information.

4.2.1 Sensepoint XCD flammable gas sensors

Sensepoint XCD flammable gas sensors are ATEX approved for use in Zone 1 or 2 hazardous areas. Two versions are available: IR and CAT versions. For more sensor specific details, refer to the Quick Start Guide of Sensepoint XCD Remote Flammable Sensor (PN: 3001M5022_1).

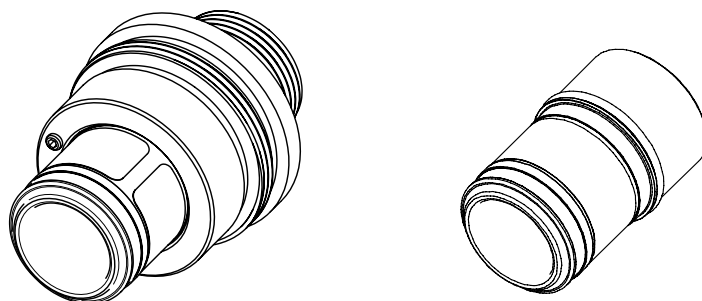

Diagram 3: Sensepoint XCD Flammable Sensor and Plug-in Cartridge

4.2.2 Sensepoint LEL Flammable gas sensors

Standard LEL Version

The standard LEL sensor is available for use in temperatures up to 80°C and detects gas concentrations up to 100% LEL of a target gas with a resolution in the region of 1% LEL, depending on the gas being detected. The sensor is available with M25 thread. M20 or 3/4" NPT threads are options.

High temperature LEL Version

The high temperature version is available for use in temperatures up to 150°C and ranges of 0-20%LEL or 0-100%LEL depending on transmitter or controller. The sensor is available with M25 thread. M20 or 3/4" NPT threads are options.

Details of connecting these sensors with the Sensepoint XCD RFD transmitter are given in sections 5 and 6. For more sensor specific details, refer to the Technical Handbook Part No. 2106M0502 or their individual manuals (Sensepoint HT Sensor Quick Start Guide Part No: 2106M0523, Sensepoint LEL Operating Instructions Part No: 2106M0501).

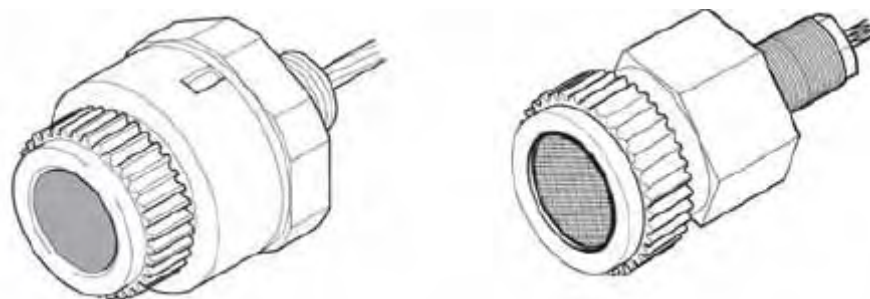

Standard LEL version

High Temperature LEL version

Diagram 4: Sensepoint LEL flammable sensors

4.3 Accessories

A range of accessories are available to allow use of Sensepoint XCD RFD in a wide variety of applications. These include Pipe mounting bracket, Sunshade deluge cover, Sensor collecting cone, Sensor flow Housing and Remote sensor mounting junction boxes.

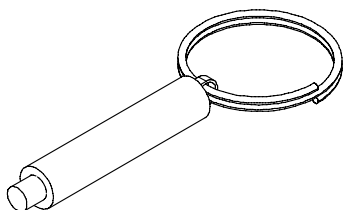

Magnetic Wand

The magnetic wand (P/N: S3KMAG) is used as a tool to allow the user to communicate with the Sensepoint XCD transmitter for the purpose of configuration, calibration and interrogating system status, (supplied with XCD RFD kit).

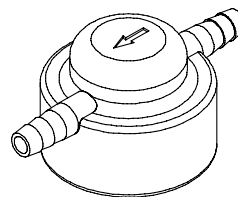

Calibration Cup

The Gassing Cap (P/N: S3KCAL) is an optional accessory that may be temporarily fitted to the sensor in place of the Weather Protection for Gas Response checking during commissioning and routine maintenance.

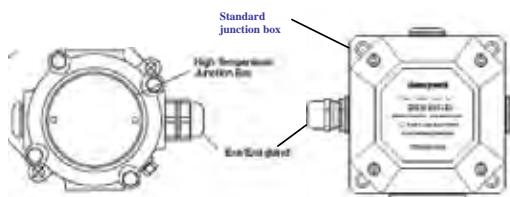

Remote Sensor Mounting

The Standard Junction Box (P/N: 00780-A-0100) and High temperature junction box (P/N: 2052D0001) are optional accessories that can be used for remote sensor mounting. Make the connection from the junction box to the transmitter using suitable cable and cable glands.

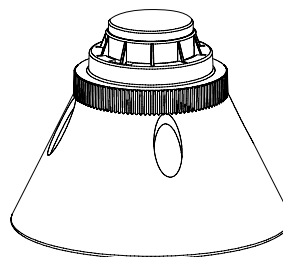

Collecting Cone

The Collecting Cone (P/N: SPXCDCC) is an optional accessory that may be fitted to the Weather Protection. The collecting cone is designed for use with gases that are lighter than air.

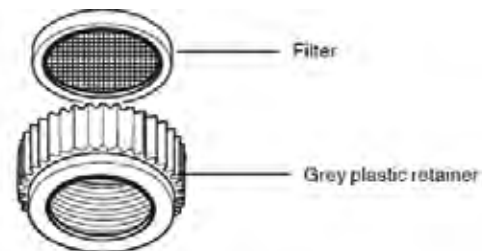

Sensepoint Filter and Filter Housing

Sensepoint Stainless steel filter (P/N: 00780-F-0018) and Filter Housing (P/N: 00780-C-0038) is an optional accessory can be used to offer additional protection to the Sinter in dry, and dusty applications.



Calibration Gas Flow Housing

The Calibration Gas Flow Housing (P/N: 02000-A-1645) may be used for either calibration of the Sensepoint sensor or if the Sensepoint sensor is to be used as part of a Aspirated Sampling System.

5 Installation

WARNINGS

Sensepoint XCD RFD is designed for installation and use in Zone 1 or 2 hazardous areas in many countries including Europe.

Installation must be in accordance with the recognized standards of the appropriate authority in the country concerned.

Access to the interior of the detector, when carrying out any work, must only be conducted by trained personnel.

Before carrying out any work ensure local regulations and site procedures are followed. Appropriate standards must be followed to maintain the overall certification of the detector.

Care should be taken when removing and refitting the Sensepoint XCD plug-in Sensor to the Sensor Socket so that damage to the connection pins can be avoided.

If using an anti-seize compound, the threads should be thinly coated with an approved silicone free compound e.g. petroleum jelly

To reduce the risk of ignition of hazardous atmosphere, de-classify the area or disconnect the equipment from the supply circuit before opening the detector enclosure. Keep assembly tightly closed during operation.

Never attempt to open a junction box/enclosure or replace/refit the sensor in potentially hazardous atmospheres while power is still applied to the transmitter.

The detector must be earthed/grounded for electrical safety and to limit the effects of radio frequency interference. Earth/ground points are provided inside and outside the unit. Ensure that all screens/instrument earth/clean earth wiring is earthed/grounded at a single point (either at the controller or detector - BUT NOT BOTH) to prevent false alarms due to earth/ground loops.

Take care when handling sensors as they may contain corrosive solutions.

Do not tamper with or in any way disassemble the sensor.

Do not expose to temperatures outside the recommended ranges.

Do not expose sensors under storage conditions to organic solvents or flammable liquids.

Refer to the local or national regulations relative to the installation at the site. For Europe see EN60079-29-2, EN60079-14 and EN61241-14.

Only assessed for ATEX for ignition hazards.

This equipment is designed and constructed as to prevent ignition sources arising, even in the event of frequent disturbances or equipment operating faults. Note: The control card must have a suitably rated fuse.

The sensor head must be fitted with the supplied weather protection, and mounted so that the sinter is pointing downward to provide ingress protection IPX6.

The weather protection is a potential electrostatic charging hazard. The manufacturer's instructions should be observed.

5.1 Mounting and location

Caution: The location of gas detectors should be made in accordance with any relevant local and national legislation, standards or codes of practice. Always replace sensors with a sensor of the same type.

Gas detectors should be mounted where a potential hazard of gas is most likely to be present. The following points should be noted when locating gas sensors.

- When locating detectors consider the possible damage caused by natural events e.g. rain or flooding.
- Consider ease of access to the gas detector for functional testing and servicing.
- Consider how escaping gas may behave due to natural or forced air currents.

Note: The placement of gas detectors should be determined following the advice of experts having specialist knowledge of gas dispersion, experts having knowledge of the process plant system and equipment involved, safety and engineering personnel. The agreement reached on the location of detectors should be recorded.

5.2 Mounting the transmitter

The Sensepoint XCD RFD transmitter has an integral mounting plate consisting of four mounting holes on the transmitter body. The transmitter may be fixed directly to a surface mounting, or to a horizontal or vertical pipe/structure, 40.0-80.0mm (1.6 to 3.1 inches) in diameter/cross section. The Pipe Mounting Bracket accessory (optional accessory) may be used for this purpose.

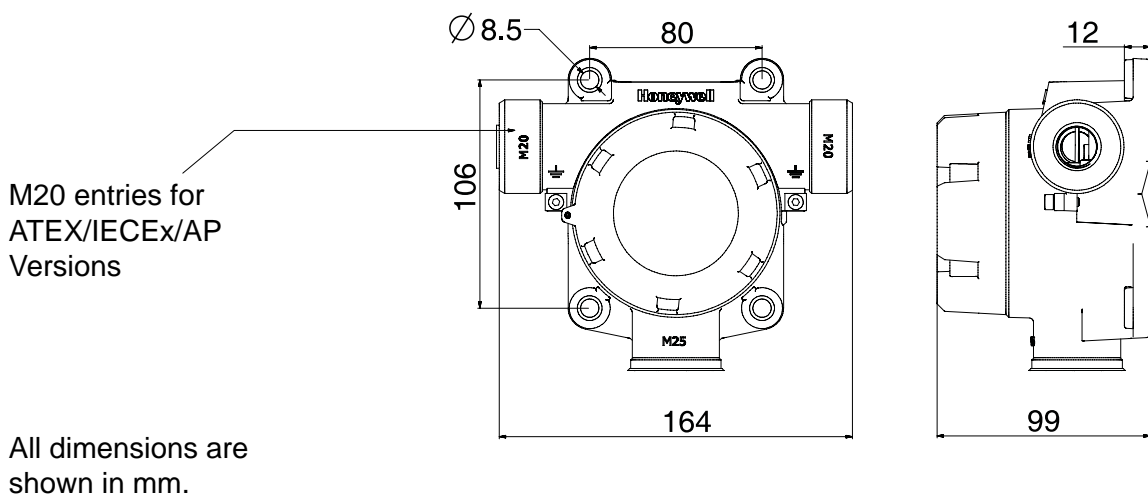

Diagram 5: Outline and mounting dimensions

5.3 Installing the sensor

WARNINGS

Care should be taken when removing and refitting the Sensepoint XCD plug-in Sensor to the Sensor Socket so that damage to the connection pins can be avoided.

If using an anti-seize compound, the threads should be thinly coated with an approved silicone free compound e.g. petroleum jelly

Take care when handling old sensors as they may contain corrosive solutions.

Take care when removing or replacing the Sensor Retainer as there may be sharp edges present on the adjoining threads.

The equipment is designed and constructed as to prevent ignition sources arising, even in the event of frequent disturbances or equipment operating faults.

Only assessed for ATEX for ignition hazards.

The sensor head must be fitted with the supplied weather protection, and mounted so that the sinter is pointing downward to provide ingress protection IPX6.

The weather protection is a potential electrostatic charging hazard. The manufacturer's instructions should be observed.

A remotely mounted sensor should be mounted using a suitable junction box . For further details regarding mounting sensors to suitable junction boxes refer to the relevant sensor manual.

1. Connect the remote sensor/junction box to the Sensepoint XCD RFD transmitter using suitable cable with wires of diameter 1mm^2 (17 AWG).
2. Connect the cable to the transmitter enclosure via the bottom entry.
3. Cable (non conduit) based installations must use appropriately certified cable glands.

Note: The maximum cable length between the remotely mounted sensor and the Sensepoint XCD RFD transmitter is 30 meters (100 feet).

4. Terminate the wires from the sensor in the transmitter as shown in chapter 6.2.
5. Select sensor type at configuration menu after remote sensor mounting. Refer to the chapter 12.1 Sensor Replacement and the chapter 13.3.1 Sensor Selection.

Sensepoint XCD RFD with Sensepoint Remote Sensor

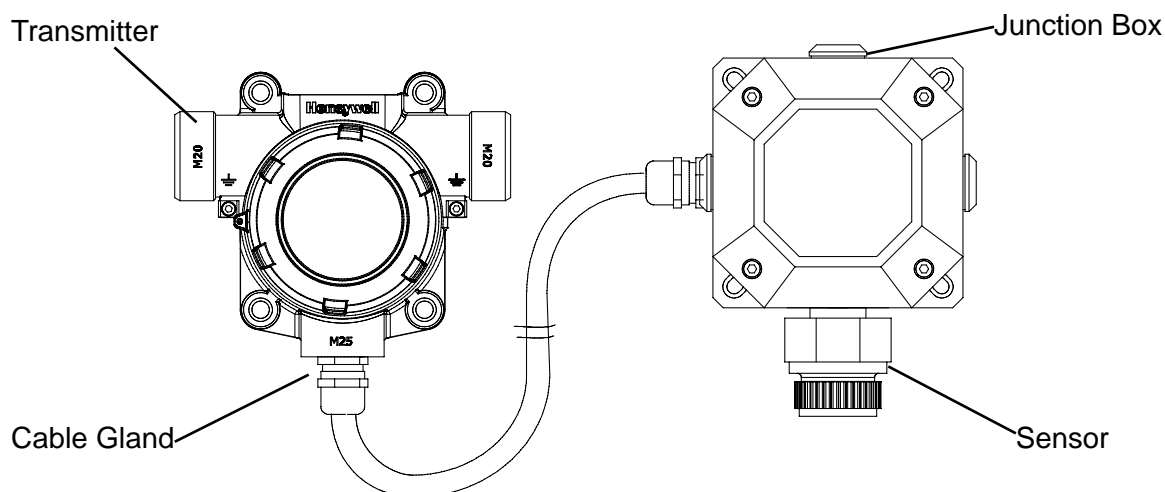

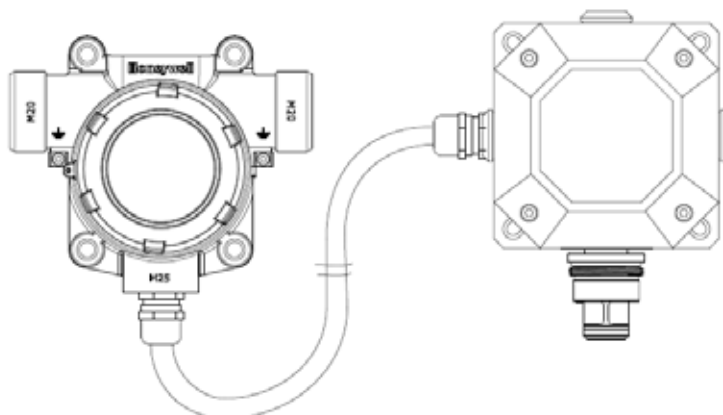
Sensepoint XCD RFD with Sensepoint XCD remote plug-in sensor

It is necessary to use a ferrite filter at the remote sensor to reduce electromagnetic interference. The ferrite filter (supplied) should be fitted as follows:

1. Screw the sensor into the remote junction box.
2. Open the ferrite filter.
3. Wind the sensor leads 2 turns round the ferrite filter.
4. Close the ferrite filter.
5. Follow instructions in the individual sensor manuals to complete installation.



6 Electrical connections

WARNINGS

Sensepoint XCD RFD is designed for installation and use in Zone 1 or 2 hazardous areas in many countries including Europe.

Installation must be in accordance with the recognized standards of the appropriate authority in the country concerned.

Access to the interior of the detector, when carrying out any work, must only be conducted by trained personnel.

Before carrying out any work ensure local regulations and site procedures are followed. Appropriate standards must be followed to maintain the overall certification of the detector.

Care should be taken when removing and refitting the Sensepoint XCD Sensor Cartridge to the Sensor Socket so that damage to the connection pins can be avoided.

If using an anti-seize compound, the threads should be thinly coated with an approved silicone free compound e.g. petroleum jelly

To reduce the risk of ignition of hazardous atmosphere, de-classify the area or disconnect the equipment from the supply circuit before opening the detector enclosure. Keep assembly tightly closed during operation.

Never attempt to open a junction box/enclosure or replace/refit the sensor in potentially hazardous atmospheres while power is still applied to the transmitter.

The detector must be earthed/grounded for electrical safety and to limit the effects of radio frequency interference. Earth/ground points are provided inside and outside the unit. Ensure that all screens/instrument earth/clean earth wiring is earthed/grounded at a single point (either at the controller or detector - BUT NOT BOTH) to prevent false alarms due to earth/ground loops.

Take care when handling sensors as they may contain corrosive solutions.

Do not tamper with or in any way disassemble the sensor.

Do not expose to temperatures outside the recommended ranges.

Do not expose sensors under storage conditions to organic solvents or flammable liquids.

Refer to the local or national regulations relative to the installation at the site. For Europe see EN60079-29-2, EN60079-14 and EN61241-14.

6.1 Transmitter Wiring

Caution: All electrical connections should be made in accordance with any relevant local or national legislation, standards or codes of practice.

The Sensepoint XCD RFD transmitter may be wired in either Current SOURCE or Current SINK configuration. These two options are offered to allow greater flexibility in the type of control system that it can be used with. SOURCE/SINK is selectable via the switch located on the back side of the display module; accessible by removing the display module during installation / commissioning (see section 9).

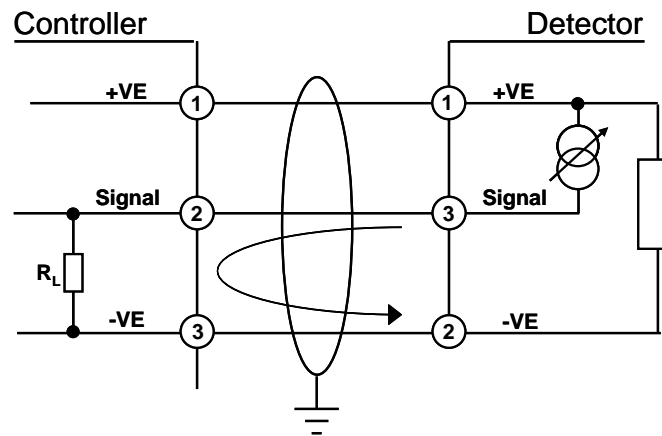

XCD Source 3 Wire 4-20mA (Source)

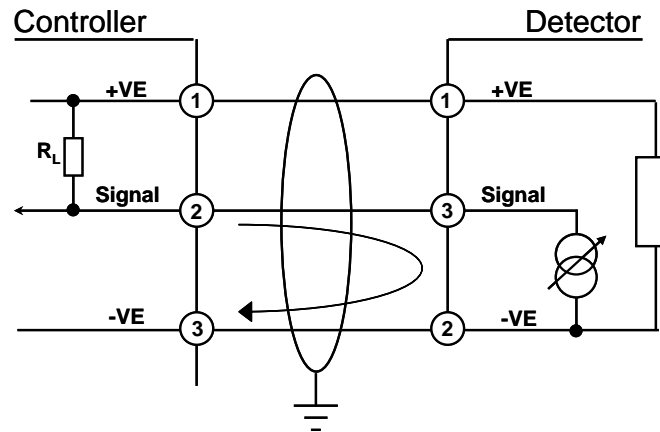

XCD Sink 3 Wire 4-20mA (Sink)

Note: Terminate cable screen at detector or controller, not both.

Caution: 250ohm load resistor (RL) is installed in the factory, In case of connection with controller, this resistor should be removed because controller has load resistor internally.

6.2 Terminal connections

Note: Ensure that none of the wires in the terminal area cause an obstruction when refitting the Display Module. Ensure that the socket on the Display Module is fully engaged in the Display Module Connector on the Terminal Module.

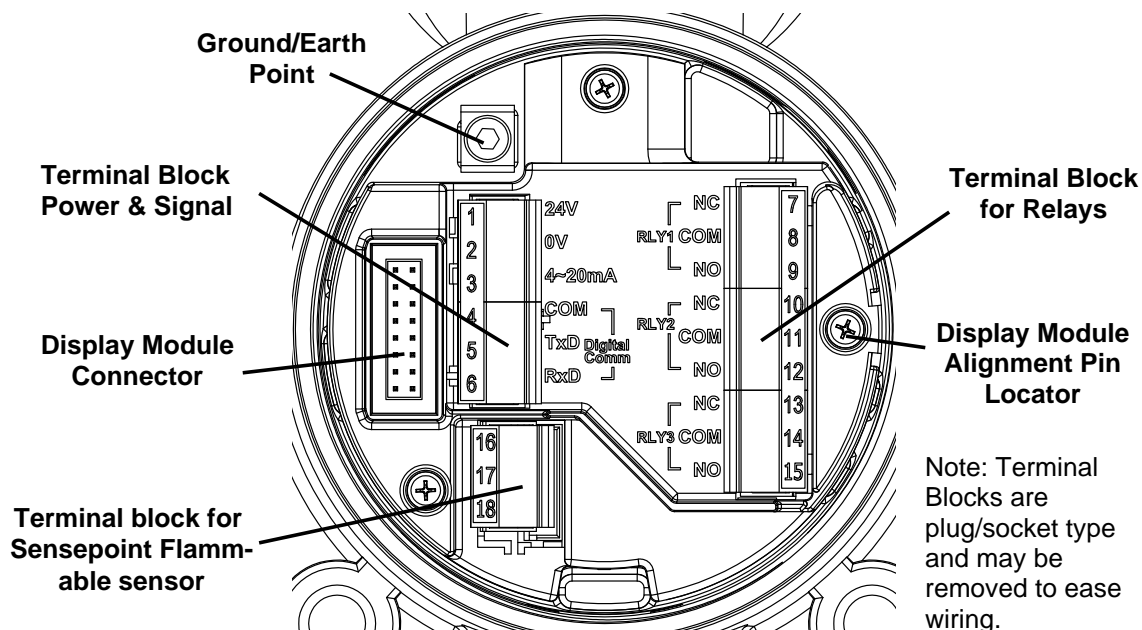

Diagram 6: Sensepoint XCD RFD Terminal module

Terminal Module Connections			
Terminal Number	Marking	Connection	Description
1	24V	+VE Supply(16-32VDC)	Controller Connections
2	0V	-VE Supply(0VDC)	
3	4~20mA	Current Output Signal	
4	COM	Common	MODBUS RTU. RS485 (Optional)
5	TxD	MODBUS A(+)	
6	RxD	MODBUS A(-)	
7	RLY1/NC	Normally Closed	Programmable Relay 1 (Default A1)
8	RLY1/COM	Common	
9	RLY1/NO	Normally Open	
10	RLY2/NC	Normally Closed	Programmable Relay 2 (Default A2)
11	RLY2/COM	Common	
12	RLY2/NO	Normally Open	
13	RLY3/NC	Normally Closed	Programmable Relay 3 (Default Fault)
14	RLY3/COM	Common	
15	RLY3/NO	Normally Open	
16	+VE	Sensitive (Sensor Brown Wire)	RFD Sensor Connection
17	-VE	Non-Sensitive (Sensor Blue Wire)	
18	01	Signal (Sensor White Wire)	

Table 1: Transmitter terminal connections

Note: The Sensepoint HT sensor must be earthed either at the remote junction box or at the transmitter as appropriate. Avoid earth loops.

6.3 Power

The Sensepoint XCD transmitter requires a power supply from the controller of between 16Vdc and 32Vdc. Ensure that a minimum supply of 16Vdc is measured at the sensor, taking into account the voltage drop due to cable resistance.

The maximum loop resistance in the field cable is calculated as follows

$$R_{loop} = (V_{controller} - V_{detector\ min}) / I_{detector}$$

Example;

The controller is supplying a nominal 24Vdc ($V_{controller}$), the detector minimum allowable voltage is 16Vdc ($V_{detector\ min}$), therefore the maximum allowable voltage drop between the controller and detector is 8Vdc; this means a voltage drop of 4V in each core (+ve core and -ve core).

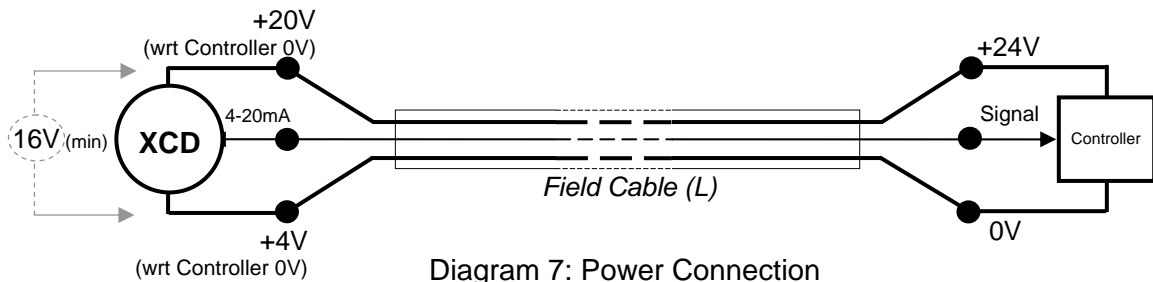

Diagram 7: Power Connection

Power consumption of the detector is 5.0W. The current required to drive the detector at the minimum voltage is ($I = P / V$), $5 / 16 = 312.5\text{ mA}$ ($I_{detector}$).

So, the maximum fieldcable loop resistance (R_{loop}) = $8 / 0.31 = 26\text{ Ohms}$, or 13 Ohms per core, (allowing for component variations, losses, etc.).

The following tables show the maximum cable distances between the controller and transmitter assuming a voltage drop of 4V in each core and for different cable parameters. The tables are examples only and actual cable parameters and source power supply voltage for the application should be used to calculate the maximum cable distance allowed at the installation site.

Typical cable data		Maximum Cable length (L)	
Cable size (cross sectional area)	Cable resistance Ω/km (Ω/mi)	Meters	Feet
0.5mm ² (20AWG*)	36.8 (59.2)	353	1158
1.0mm ² (17AWG*)	19.5 (31.4)	666	2185
1.5mm ² (16AWG*)	12.7 (20.4)	1023	3356
2.0mm ² (14AWG*)	10.1 (16.3)	1287	4222
2.5mm ² (13AWG*)	8.0 (12.9)	1621	5318
*nearest equivalent			

Table 2: Maximum cable distances

6.4 Cabling

The use of industrial grade, suitably armoured field cable is recommended.

For example, screened 3 cores (plus screen 90% coverage), suitably mechanically protected copper cable with a suitable M20 explosion-proof gland with 0.5 to 2.5 mm² (20 to 13 AWG) conductors. Ensure the cable gland is installed correctly and fully tightened. All unused cable entries must be sealed with a suitable certified sealing plug (one plug is supplied).

Remote Mounting Cable Details

Type	Cable Spec	Max Length
RFD Remote	AWM2464 AWG20~AWG14 Shield	30meters

Note: The Sensepoint HT sensor requires an earth core if the remote junction box does not have a suitable earth point.

6.5 Cable and Earth/Ground regimes

Effective Earth/Ground bonding is important to ensure good EMC and RFI immunity.

The following diagrams show examples of how to earth/ground bond the cable at enclosures. These bonding techniques provide good RFI/EMC performance. Earth/ground loops must be avoided to prevent the risk of false signal variation.

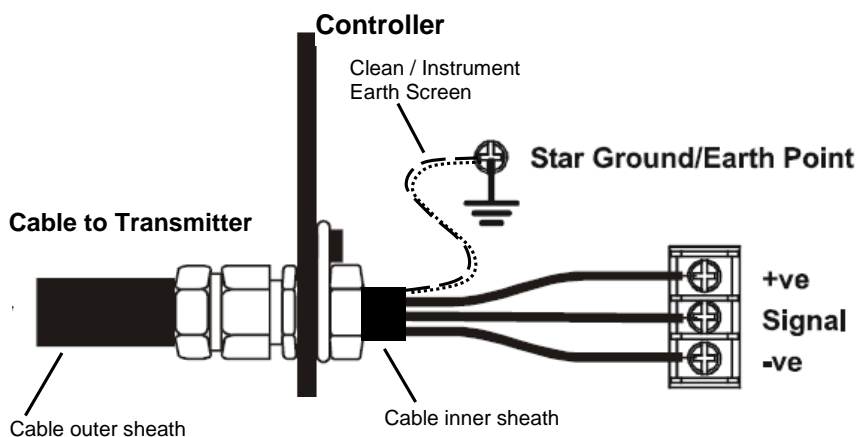

Diagram 8: Controller Grounding

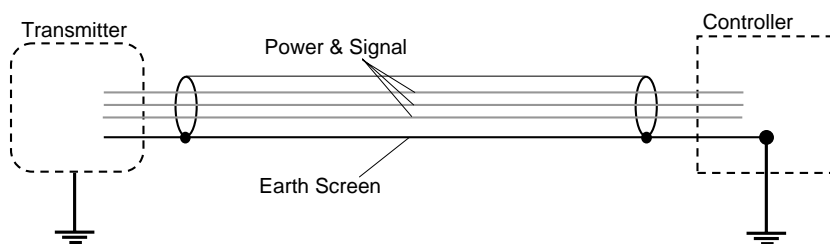

Diagram 9: System grounding

The Earth Screen of the field cable should be “tied to Earth” or connected to Ground at one point only. It is common practise to adopt a STAR EARTH connection regime where all instrumentation Screens are connected at one common point.

The Screen at the other end of the cable should be “parked” or terminated into a blank terminal.

The following diagrams show how to install the wire into the ground screw of the enclosure.



6.6 Ground Terminal Wiring

Internal Ground connection: Utilize the shield of the wiring cable recommended in the wiring instructions. For connection to this terminal. Twist the shield wire to avoid stray shield wires, Loosen the screw sufficiently and wrap the wire around the screw in a “U” shape. Raise the clamp and place the wire between the clamp and ground base, lower the clamp and tighten the screw to 6.9lb-in torque.

External Ground Connection: If required by local authority, Utilize a No 14 AWG copper, (Stranded or Solid), wire. Loosen the screw sufficiently to enable ‘wrapping the wire around the screw in a “U” shape. Raise the clamp and place the wire between the clamp and ground base, lower the clamp and tighten the screw to 10.4lb-in torque. A suitable Ring or Spade type insulated crimp terminal may also be used to accommodate the M4 size external earth screw.

7 Default configuration

The Sensepoint XCD RFD transmitter is supplied with the following default configuration.

Function	Value/Setting	Meaning
Sensor Type	Automatic for Sensepoint XCD RFD sensors. Must be set for Sensepoint sensors.	XCD RFD recognizes the XCD RFD sensor cartridge according to the gas type within its own sensor family i.e. mV. For a Sensepoint sensor the user must set the sensor type.
Signal output	≥0.0<1.0 mA	Fault (refer to table 9 section 12.3 for details)
	2.0 mA or 4.0 mA	Inhibit (during configuration/user settings)
	4.0 mA to 20.0 mA	Normal gas measurement
	22.0 mA	Maximum over range
Alarm Relay 1*	Value is sensor dependant	Lower alarm level
	De-energized	Energizes on alarm
	Contact Normally Open (NO)	Closes on alarm
Alarm Relay 2*	Value is sensor dependant	Higher alarm level
	De-energized	Energizes on alarm
	Contact Normally Open (NO)	Closes on alarm
Fault Relay	<1mA	Detector Fault
	Energized	De-energizes on alarm
	Contact Normally Open (NO)	Closes on alarm
Inhibit	2.0 mA (default)	Signal output inhibited during menu use If any relay is set to inhibit relay, then inhibit relay will be activated.
Timeout	Disabled	No inhibit timeout. The detector waits for a button press before returning to the previous state/setting Timeout period can be set in 'Configure Inhibit' menu in Configuration Mode.
Password	0000 (Disabled)	0000 (Password disabled). If changed then password is activated.
Location (Tag Number)	0000	Optional feature to identify the location or User's "Tag" number of the XCD
Temperature	°C	Option to have °C or °F

* Alarm relays automatically reset when reading falls within alarm thresholds. If relay configured to LATCH, then relays must be reset using the Magnetic Wand.

Table 3: Default configuration

Gas Name	Default Range	Lower Alarm	Lower Alarm Type	Higher Alarm	Higher Alarm Type
Sensepoint Flammable	100%LEL	20%LEL	Rising	40%LEL	Rising
Sensepoint HT Flammable	100%LEL	20%LEL	Rising	40%LEL	Rising
Sensepoint HT Flammable	20%LEL	10%LEL	Rising	15%LEL	Rising
XCD Flammable CB*	100%LEL	20%LEL	Rising	40%LEL	Rising
XCD Methane IR	100%LEL	20%LEL	Rising	40%LEL	Rising
XCD Propane IR*	100%LEL	20%LEL	Rising	40%LEL	Rising
Carbon Dioxide*	2.00%Vol	0.40%Vol	Rising	0.80%Vol	Rising

*Contact Honeywell Analytics for availability

For details of how to change the configuration of the Sensepoint XCD please refer to section 13.

8 Normal Operation

Sensepoint XCD RFD is supplied configured and ready for use according to the “Default Settings” table shown above. However these setting may be tailored to a specific application requirement using the Sensepoint XCD RFD configuration menu system.

Access to the Sensepoint XCD RFD transmitter’s configuration menus system is via the Magnetic Activation Tool.

8.1 Display Screen

The Sensepoint XCD RFD display features an LCD with Numeric and bar-graph gas concentration data, alpha-numeric warning and status indication, a target for magnetic switch activation and the UP/DOWN/ESC/ENTER zones for remote configuration. The LCD is also backlit with hi-intensity multi-colour LED indicator to show NORMAL, ALARM and FAULT status.

During normal operation the instrument display shows a steady GREEN backlight.

During Low and High Gas Alarm it displays a flashing RED backlight

During Fault condition the instrument display shows a flashing YELLOW backlight.

The screen is visible through the window of the transmitter’s cover. The display shows the gas concentration (both graphically and numerically), range, units, alarm/ fault status, etc.

Note: The detector display may become sluggish in sub-zero temperatures and possibly unclear at temperatures below -40 °C, but the detector continues its gas monitoring function. The display is not damaged and recovers when the temperature increases.

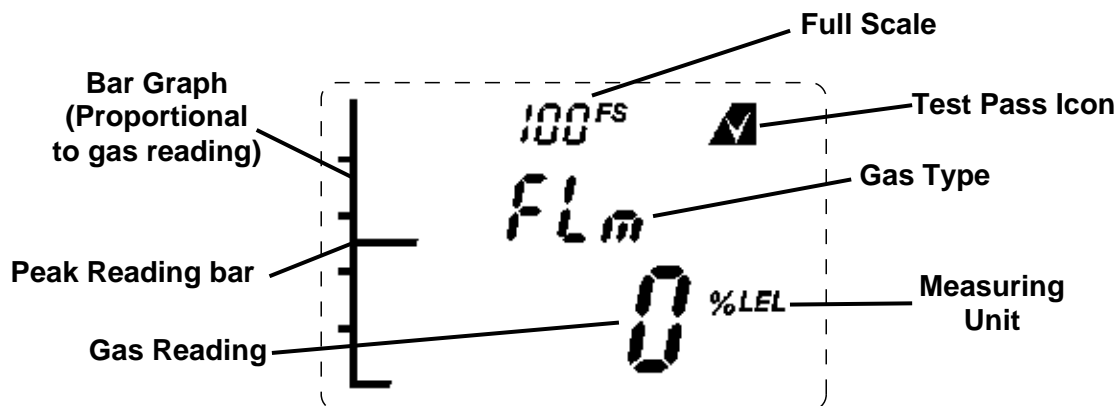

Diagram 10: Example of a Flammable Transmitter Display screen – Normal Operation

8.2 System Status

Display indications, current output and relay states for various operational conditions are shown in the following table. For further details of error messages and trouble shooting see section 12.3.

System Status						
Status	Display	Current Output	Relay			Back Light
			A1	A2	Fault	
Fault: Circuit or sensor error	F-XX fault number with fault icon blinking	0-1.0 mA			✓	Yellow, flashing
System Fault	N/A	0-0.15mA				
Note: In the event of processor failure the watchdog will automatically reset the system for recovery.						
Warning	W-XX warning number with fault icon blinking	Dependent on system status				Green Steady
Normal	0.0 Gas concentration	4-20 mA				Green Steady
Alarm 1	Gas concentration. 1 st alarm icon blinking	4-20 mA	✓			Red, flashing
Alarm 2	Gas concentration. 2 nd alarm icon blinking	4-20 mA	✓	✓		Red, flashing
Over-range	Full scale icon and reading blinking	22mA	✓	✓		Red, flashing
Inhibit	Inhibit icon dependent on Menu command. If any relay is set to inhibit relay, then inhibit relay will be activated.	2 or 4mA depending on configuration.				Green Steady

Table 4: System status

8.3 Magnetic Wand Activation

The magnetic wand is used as a tool to allow the user to communicate with the Sensepoint XCD RFD transmitter. Communication with the XCD RFD is achieved by positioning the Magnetic Wand at one of three different positions on the front glass window of the Sensepoint XCD RFD transmitter. Activation of the switches is verified by observing the Magnetic Wand Activation Icon on the LCD display

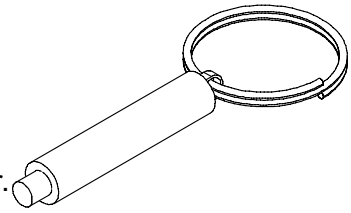

Hold the Magnetic Wand in position for up to 2 seconds = ●

Hold the Magnetic Wand in position for 3 seconds or more = ⊙

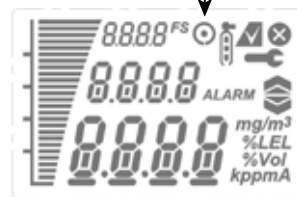

8.4 Operation Mode Structure

Sensepoint XCD RFD has 3 operating modes.

1. **Monitoring mode**, is the normal operating status while XCD RFD measures and displays gas concentration. The fault/warning status is periodically checked, relay contacts are activated according to the configuration.
2. **Configuration mode**, this mode allows parameters relating to the configuration of the Transmitter functions to be changed according to specific needs. This mode can be protected by a password mechanism to prevent unauthorised changes being made.
3. **Review mode**, allows the user to view the current configuration settings.

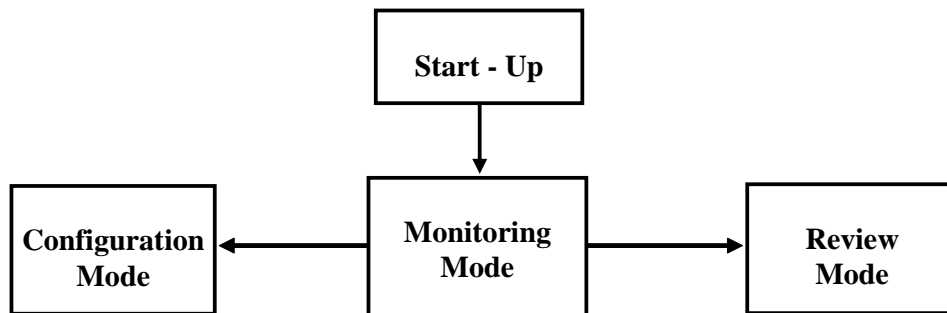

Diagram 11: Mode Structure

Further details of the information available and configuration options for the Sensepoint XCD RFD can be found in Section 13. of this manual.

9 First time switch on (Commissioning)

WARNING

The following procedure requires the Transmitter Cover to be removed while carrying out supply voltage checks. Therefore the appropriate permits to work should be sought in preparation.

Prior to carrying out any HOT WORK ensure local and site procedures are followed. Ensure that the associated control panel output actuation is inhibited so as to prevent false alarms.

Caution: *The following procedure should be followed carefully and only performed by suitably trained personnel*

Note: Calibration is mandatory before the detector can be used for gas monitoring. Refer to Section 10.1 Calibration for the proper procedure.

1. Remove the transmitter housing cover and detach the display unit by lifting the semi-circular handle and pulling the assembly directly away from the termination module (without twisting it)
2. Configure the detector's analogue output signal configuration for Current SINK or Current SOURCE operation using the selector switch located on the back of the display module. The default setting is Current SOURCE.
3. Check that all electrical connections are terminated correctly as per section 6.
4. **Switch On** the external power supply to the transmitter at the safe area gas detection controller (or PLC).
5. Using a Digital Multi Meter (DMM), check the Supply Voltage at the terminals 1 (24V) and 2 (0V), this should be a minimum supply voltage of 16Vdc (Maximum supply voltage is 32V DC)
6. **Switch Off** the external power to the detector.
7. Refit the Display Module and Cover.

Note: Ensure that none of the wires in the terminal area cause an obstruction when refitting the Display Module. Ensure that the socket on the Display Module is fully engaged in the Display Module Connector on the Terminal Module.

8. **Switch On** external power to the detector.
9. All the display icons/text/numbers are displayed for 3 seconds.

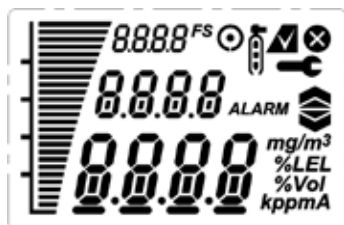

10. A start up sequence will then be displayed, similar to the one shown in Diagram 15.

Note:

For a full description of each screen shown in Diagram 12, please refer to Section 13.3 “Review Mode” of this Manual.

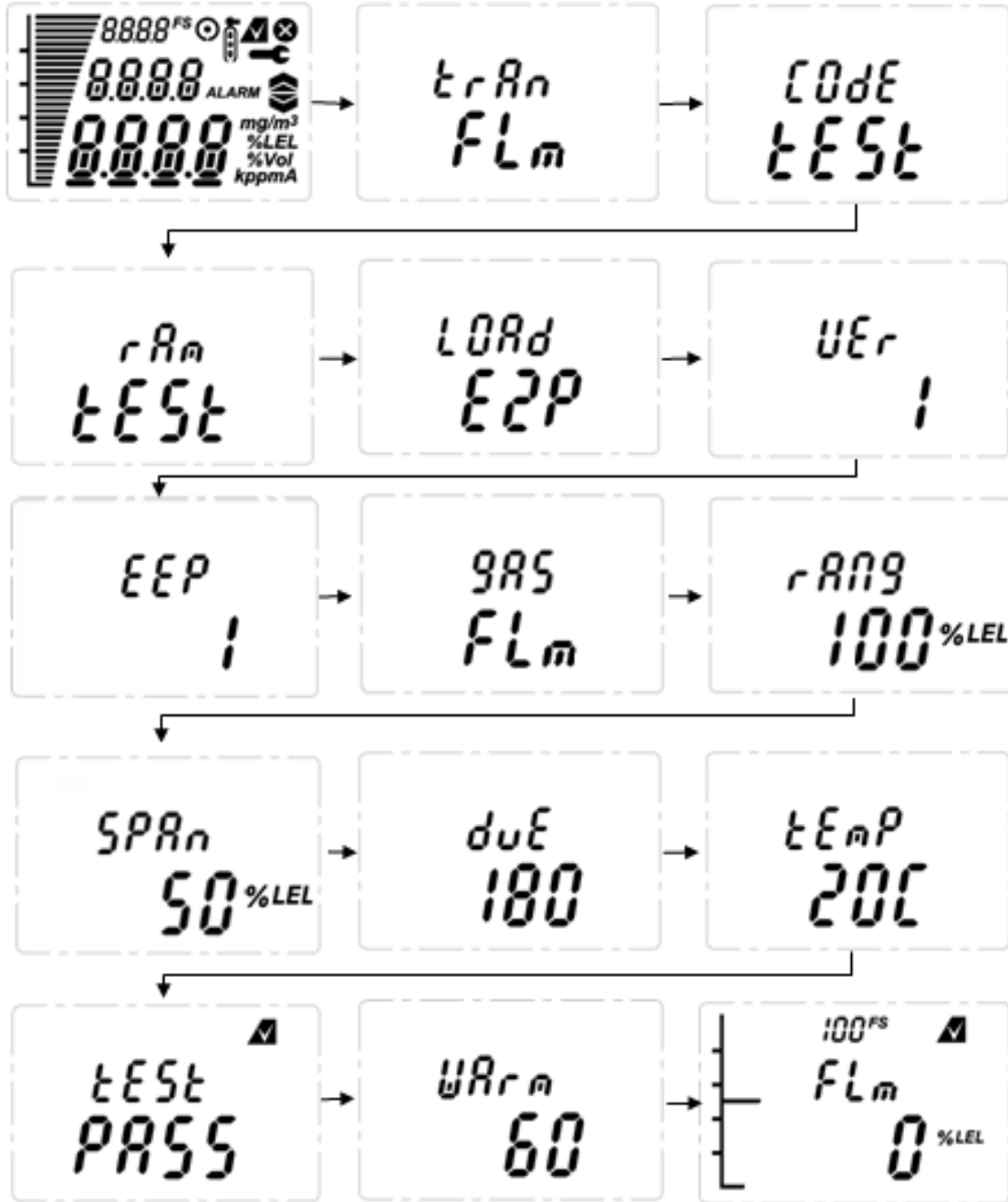

Diagram 12: Normal Start up procedure (For the Flammable sensor version)

11. The warm up countdown of 60 seconds (depending on the gas type) is then initiated.
12. Normal **Monitoring Mode** is then resumed.

10 Response Check and Calibration

It is recommended to periodically carry out a gas response check on the Sensepoint XCD RFD to ensure correct operation. This may be done in two ways;

1. A simple Response Check often referred to as a “BUMP TEST” is a test using calibration gas applied to the sensor via the nozzle of the Weather Protection or using the Sensepoint XCD RFD Gassing Cap.

If a BUMP TEST is done via the Weather Protection nozzle it may be necessary in windy conditions to increase the flow rate of the test gas by a further 1 LPM, OR, to shelter the weather protection from the wind.

2. A full gas calibration of the sensor as described in the following section, using ONLY the Sensepoint XCD Gassing Cap (Part No.: SPXCDDCAL) for the Sensepoint XCD sensor, or, using ONLY the Sensepoint Calibration Gas Flow Housing (P/N: 02000-A-1645) for the Sensepoint sensor.

10.1 Zeroing and span calibration

Caution: Before initial calibration allow the detector to stabilize for 30 minutes after applying power.

When in zeroing and span calibration mode the current output from the detector is inhibited (default 2mA) to avoid false alarms.

For Flammable gas calibration use a calibration gas concentration of between 25%LEL and 95%LEL to ensure that the required accuracy can be attained.

To calibrate the detector, use an appropriate span gas cylinder, constant flow regulator AND the Sensepoint XCD Gassing Cap (see section 4.3). The flow rates used for calibration gas are as follows:

Gas Type	Flow rate (L / Min)
Flammable	1 to 1.5
Flammable IR	0.4 to 0.6

A compressed air cylinder (20.9%Vol oxygen) should be used to perform the zero calibration if the area where the detector is located contains any residual amount of the target gas. If no residual gas is present then the background air can be used to perform the zero calibration. Contact your Honeywell Analytics representative for details of suitable calibration kits.

To calibrate the detector follow the procedure below.

(ZERO CALIBRATION)

1. If the ambient air is NOT considered reliable to use to set the ZERO, then remove the weather protection and fit the Gassing Cap accessory (see Section 4.3) onto the sensor and apply a clean source of zero gas or compressed air.
2. To access the calibration menu, hold the end of the magnet over the switch located at the top center of the detector display (✓) for at least 3 seconds and then remove.
3. The display will indicate the first configuration mode menu 'SEt CAL'.



4. Put the magnet over the '✓' switch again and move to enter the Calibration menu.
5. The display will show the current gas reading, and the '0' icon flashes.



6. When the zero gas reading is stable use '✓' to confirm zero calibration.
7. If successful the display shows 'ZEro PASS' (if not successful, the display shows 'ZEro FAIL' and returns to configuration mode).

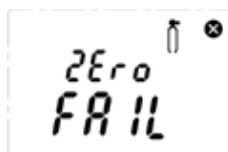
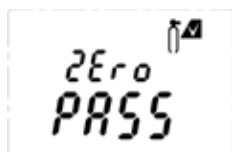

8. If using zero-air, turn it off. Zeroing is complete and saved.
9. The display shows 'SPAN' with 'YES' flashing.



10. If span calibration is required use '✓' proceed to the next step. If span calibration is not required, use '▲▼' to select 'No' and '✓' to return to configuration mode.

(SPAN CALIBRATION)

11. The display shows the current calibration span gas concentration while flashing the 'gas' icon. Use '▲▼' to change the calibration span gas concentration, and '✓' when required span calibration level is set.



12. The display will show the current gas reading, and the 'gas' icon flashes.

13. Connect the regulator to the span gas cylinder.

14. Apply the span gas to the sensor using the Sensepoint XCD Gassing Cap (see section 4.7 for description). The live gas reading is displayed. When the reading is stable, use '✓' to confirm span calibration.



15. If the sensor has been replaced the following display may be shown.



16. Use '▲▼' to select 'YES' if the sensor has been replaced or 'No' if it has not been replaced.

17. If the span calibration is successful the instrument will briefly display 'SPAN PASS' (if fails 'SPAN FAIL' displayed and returns to configuration mode).

Note: the calibration due warning counter is reset after a successful calibration. See section 12.3 for further details of setting a calibration due warning.



18. The display alternates between "Purg gAS" and the gas reading to indicate that the unit is expecting the span gas to be removed from the sensor.



19. Promptly switch off the calibration span gas and remove the Sensepoint XCD Gassing Cap from the sensor to allow the gas to disperse.
20. When the reading falls below 50% of the calibration gas level the display indicates a countdown .

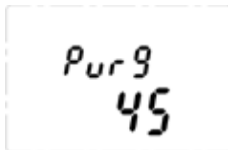

21. When the countdown is finished, the calibration procedure is complete.
22. The instrument returns to the 'Set CAL' menu. Activate the '▲' or '▼' switch to select another menu or select 'QUIT' to return to normal monitoring mode.

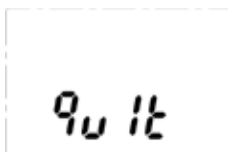

Note: Remember to always replace the Weather Protection and other accessories.

11 General Maintenance

WARNINGS

Access to the interior of the transmitter, when carrying out any work, must only be conducted by trained personnel.

Care should be taken when removing and refitting the Sensepoint XCD plug-in Sensor Cartridge to the Sensor Socket so that damage to the connection pins can be avoided.

Before carrying out any work ensure local regulations and site procedures are followed. Appropriate standards must be followed to maintain the overall certification of the sensor and transmitter.

To reduce the risk of ignition of hazardous atmosphere, de-classify the area or disconnect the equipment from the supply circuit before opening the transmitter enclosure. Keep assembly tightly closed during operation.

Never attempt to open a junction box/enclosure or replace/refit the sensor in potentially hazardous atmospheres.

Take care when handling sensors as they may contain corrosive solutions.

Do not tamper with or in any way disassemble the sensor.

Do not expose to temperatures outside the recommended ranges.

Do not expose sensors under storage conditions to organic solvents or flammable liquids.

For remote Flammable sensors used with the XCD RFD Transmitter, please refer to the individual sensor manual for specific recommended calibration periods.

11.1 Operational Life

The pellistors used in the Catalytic flammable gas sensor can suffer from a loss of sensitivity when in the presence of poisons or inhibitors, e.g. silicones, sulphides, chlorine, lead or halogenated hydrocarbons. The pellistors are poison resistant to maximize the operational life of the Catalytic flammable sensor. A typical operating life, subject to the presence of poisons/inhibitors is 36 months.

The NDIR (infrared) flammable gas sensor is not affected by the above-mentioned poisons and therefore has a longer life span. A typical operating life is 5 years.

Refer to section 12 for sensor replacement procedures.

12 Servicing

WARNINGS

Take care when handling sensors as they may contain corrosive solutions. Do not tamper or in any way dis-assemble the sensor. Do not expose to temperatures outside the recommended range. Do not expose sensor to organic solvents or flammable liquids.

Care should be taken when removing and refitting the Sensepoint XCD plug-in Sensor Cartridge to the Sensor Socket so that damage to the connection pins can be avoided.

Caution: The following procedure should be followed carefully and only performed by suitably trained personnel.

A fault condition will be signalled by the detector if the sensor is removed with the unit under power.

12.1 Sensor replacement

The sensors that are used with the Sensepoint XCD RFD have no serviceable parts. When they have reached the end of their operational life, simply replace the sensor or the sensor cartridge.

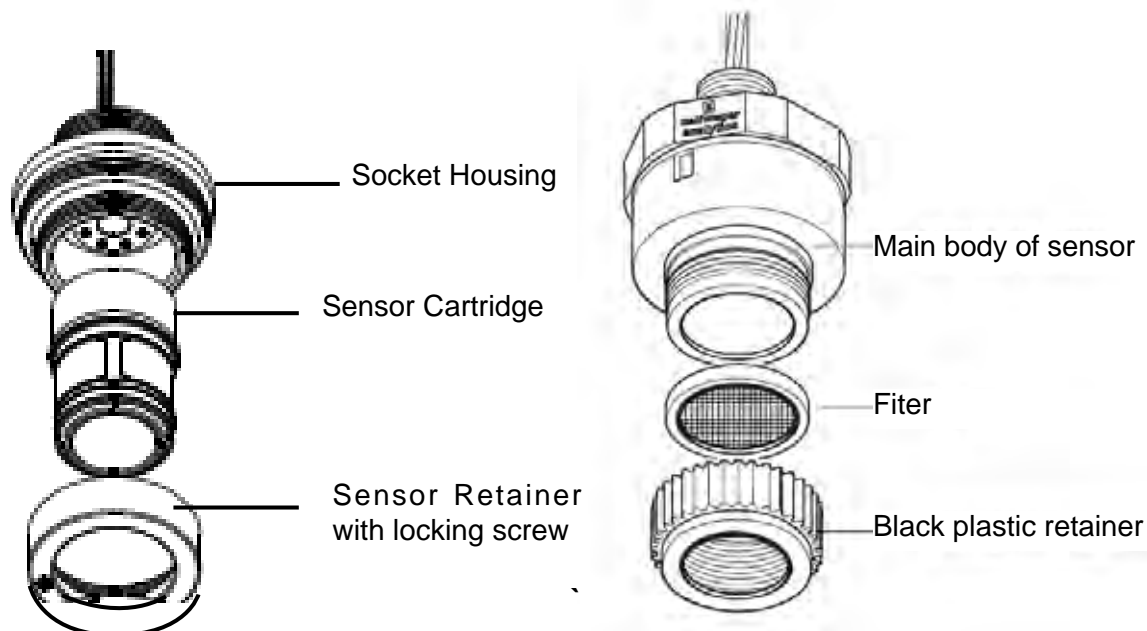

Diagram 13: Sensor Replacement

Only a qualified installation engineer should service the sensor. Ensure power is off before carrying out any maintenance procedures. The only maintenance required is sensor replacement and filter changing (if fitted to an accessory). To replace the complete sensor refer to the Quick Start Guide of Sensepoint XCD Remote Cartridge (PN: 3001M5022_1).

To replace remote sensor of a Sensepoint XCD Flammable Sensor Socket use the following procedure:

1. **Important:** Remove the Power from the Sensepoint XCD RFD Transmitter
2. Remove other accessories from the sensor socket thread.
3. Remove the Sensor Retainer with locking screw.
4. Remove the old Sensor Cartridge and replace with a fresh Sensor Cartridge.
5. Screw the accessory firmly onto the sensor until it seats against the sensor body hexagon.
6. After fitting the new sensor, reapply power to the XCD RFD transmitter.

Note: It is possible that an F04 fault message may show on the XCD RFD display if the new replacement sensor type does not exactly match with the original sensor it is replacing. In this case, select sensor type from the Configuration menu. Please refer to section 13.3.1 Sensor Selection. Remove the F04 fault message by entering review mode. Refer to section 13.4. Review mode.

7. Select sensor type at configuration menu after remote sensor mounting. Refer to the chapter 13.3.1 Sensor Selection.
8. And then remove fault message by entering review mode. Refer to the chapter 13.4. Review mode.

WARNING

Ensure that the same Gas Type and Range of Sensor is fitted in place of the old Sensor.

Care should be taken when removing and refitting the Sensepoint XCD plug-in Sensor Cartridge to the Sensor Socket so that damage to the connection pins can be avoided.

The sensor head must be fitted with the supplied weather protection, and mounted so that the sinter is pointing downward to provide ingress protection IPX6.

The weather protection is a potential electrostatic charging hazard. The manufacturer's instructions should be observed.

CAUTION

The 4-20mA analogue output signal will remain INHIBITED at 2mA (default setting) while the XCD RFD remains in Configuration Mode. However, the ALARM and FAULT RELAYS remain Active.

Changing the configuration of the Sensor Type or the Gas Star Rating for catalytic sensors may result in temporary activation of the ALARM or FAULT RELAYS. Should this occur, then recalibrating the sensor will return the XCD RFD to normal condition and reset the relays.

As a precaution, please take necessary action to manually inhibit any external actuator or alarm devices that are connected to the XCD RFD Alarm/Fault Relays to prevent unnecessary activation during commissioning or reconfiguration of the XCD RFD gas detector.

To replace the Sensepoint LEL sensor please refer to the Sensepoint Technical Handbook Part No. 2106M0502

12.2 Replacing Modules within the Transmitter

Two replaceable module assemblies are located within the transmitter housing. The Display Module and the Terminal Module.

The Display Module is simply removed by unplugging it from the Terminal Module (this procedure is done during normal installation).

To replace the Terminal Module, use the following procedure:

1. Unscrew and remove the Transmitter Cover
2. Lift the handle and un-plug and remove the Display Module.
3. Unplug the connection terminals and lift them clear of the Terminal Module.
4. Unplug the connector for the XCD sensor.
5. Loosen and remove the three “cross-headed” screws that secure the Terminal Module to the Transmitter housing.
6. Carefully lift the Terminal Module from the transmitter housing.
7. Fit the new Terminal Module using the above procedure in reverse order.

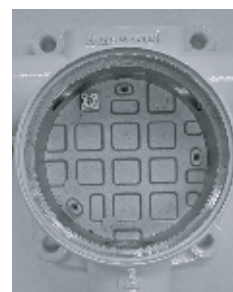
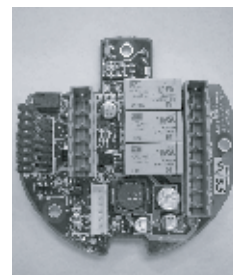
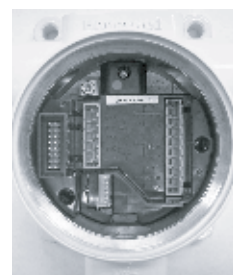

12.3 Faults and Warnings

The table below provides details of possible error.

Message	Description	Action
W-01	Calibration needed	The unit has not been calibrated for the configured calibration interval Calibration is necessary due to change of sensor/gas type
W-02	Transmitter Temperature limits exceeded	Use '✓' to clear when within limits
W-03	Alarm setting needs to be configured	Re-configure alarm settings such that upper alarm should not exceed user configured scale
W-04*	Over-range warning	Use '✓' to clear when within limits
W-05*	The sensor is switched off to prevent it from being deteriorated	Make sure that there is no flammable gas in the air and use '✓' to clear when within limits
F-01	Internal I2C failure	Cycle power to detector. Replace detector
F-02	Cell failure	For Flammable/IR, cycle power to detector. Replace sensor
F-03	Significant zero drift	Re zero/calibrate
F-04	Unexpected sensor fitted	Replace sensor
F-05	EEPROM is corrupted	Reset transmitter. If fault still appear, replace transmitter
F-06	Low supply voltage	Reset transmitter. If fault still appear, replace transmitter
F-07	SRS processor failure	Reset transmitter. If fault still appear, replace transmitter
F-08	RAM read/write fault	Reset transmitter. If fault still appear, replace transmitter
F-09	Info. memory corrupted	Reset transmitter. If fault still appear, replace transmitter
F-10	Code Memory corrupted	Reset transmitter. If fault still appear, replace transmitter
F-11	DAC output failure	Check load resistor or sink/source mode switch was configured properly
F-12	Heater failure	Reset transmitter. If fault still appear, replace transmitter
F-13	Supplied voltage failure	Check supply voltage. Replace detector

*Note : W-04 and W-05 are only for flammable catalytic bead sensors. For other gases, gas reading will blink on the LCD instead of the over-range warning.

Table 9: Fault and Warning List

13 Menu's and Advanced Configuration

13.1 Abort Function

In Review Mode or Configuration Mode the user can escape one step back from the current position using the Abort Function. To do this the user must activate the Enter switch for more than 3 seconds with the Magnetic Wand. Switching between each pair of modes or between menus and sub menus are shown in the following table.

From	To	Example
Review Mode	Monitoring Mode	Activate Enter switch for more than 3 seconds while in Review Mode
Configuration Mode	Monitoring Mode	Activate Enter switch for more than 3 seconds while navigating menus in the Configuration Mode
Configuration Mode sub menu	Configuration Mode main menu	Activate Enter switch for more than 3 seconds while in a sub menu

Table 10: Transmitter menu switching

13.2 Configuration Mode

The table below shows the functions available via the configuration menu that can be displayed on the transmitter and accessed using the Magnetic Wand.











The instrument will show the main Menu when the “Enter” switch is activated with the Magnetic Wand and held for at least 3 seconds.

The Menu is password protected to prevent any unauthorized changes. The password is initially disabled and the default password is ‘0000’. If the default password is changed to other than ‘0000’, then the password is enabled automatically and requested when entering Configuration Mode.

With the Menu showing, the following functions can be performed: calibration, bump test, sensor selection and configuration of parameters such as measuring range, calibration gas level, calibration interval, inhibit current, inhibit timeout, alarm setting, relay setting, password change, location setting, temperature unit reading, force analogue output and alarm function checks.

While in Configuration mode, the output current of the transmitter is inhibited to prevent false alarms.

Names, displays and descriptions for each menu item in Configuration Mode are shown in the following table.

Menu	Display	Description
Set Calibration		Execute zero/span calibration Set calibration gas level After zero, the option exists to proceed with span calibration, or return to the Menu.
Select Sensor		Select the type of sensor from the sensor list. This menu is only available for flammable / IR sensor.
Select Gas		Select the type of gas from the list. This menu is only available for flammable / IR sensor.
Set Range		Set measuring range
Configure Inhibit		Select inhibit current Set timeout option (5 minute increments)
Set Password		Enable/disable password Set password Default – no password (Select '0000')
Set Calibration Interval		Set calibration interval, 30 to 365 days User configurable option to display warning
Bump Test		Execute a 'bump' test to check gas response of the sensor.
Force Current		Force analogue output to test functionality of GD control system during system commissioning.
Set Alarms		Set alarm 1, alarm 2 levels, functionality and operation (none/falling/rising)
Set Relays		Set relay 1,2,3 type (alarm 1, alarm 2, fault and inhibit) and action (energized/de-energized)





Relay Operation		Configure relay on delay time, relay off delay time and latch/non-latch
Set Location		Set location (or TAG number)
Set Temperature Unit		Change temperature display unit. °C (Celsius) or °F (Fahrenheit)
Check Alarm functions		Simulate alarm situation to check the alarm system without gas present at the sensor
Quit		Return to Monitoring mode

Table 11: Transmitter menu descriptions

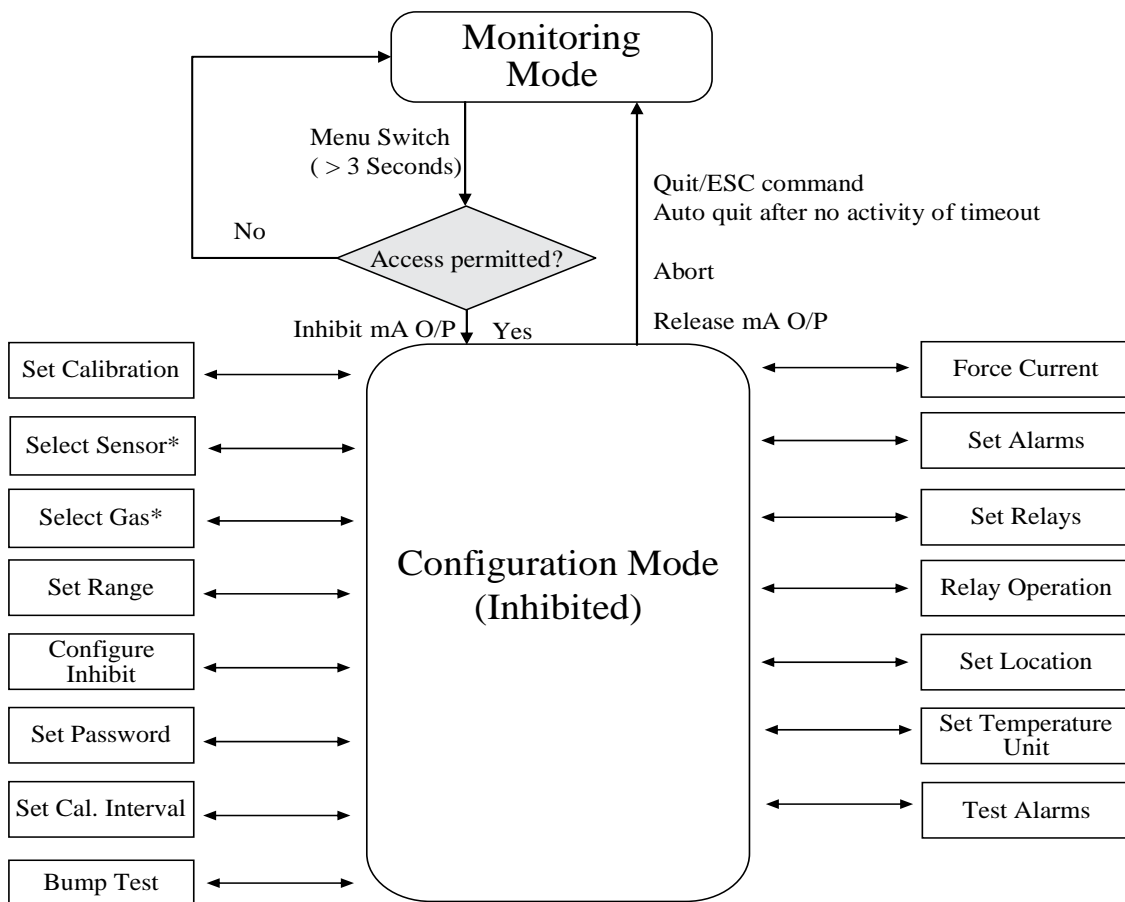





Diagram 14: Configuration Mode

13.2.1 Configuration mode operation table

Configuration mode allows the user to perform calibration and configure parameters such as full scale range, calibration gas level, calibration interval, inhibit current & timeout, alarm settings, relay settings, set a password, etc. To activate Configuration mode hold the magnet over the ENTER switch for at least 3 seconds and then remove. Configuration mode can be password protected to prevent unauthorized personnel from changing parameters. Initially the password is set to '0000' meaning it is disabled. While in Configuration mode, the output current of the detector is inhibited to prevent false alarms. Use the table below to help navigate the menus and make configuration changes. The menus are shown in the left hand column. Use ▲▼ to select the required menu and '✓' to enter. Follow the information and instructions in the table from left to right from the required menu.

▲▼	OK	▲▼	OK	▲▼	OK	▲▼	OK	▲▼
SEt CAL ¹	✓	GAS NAME, ZERO CONCENTRATION AND FLASHING '⌘' ICON DISPLAYED. APPLY ZERO GAS AND USE '✓' WHEN READING IS STABLE. 'ZEro PASS' DISPLAYED IF OK, 'ZEro FAIL' IF NOT.	⇒	'SPAN' DISPLAYED AND 'YES' FLASHING TO ASK IF YOU NOW WANT TO PERFORM SPAN CALIBRATION. USE '✓' TO PROCEED OR USE ▲▼ TO SELECT 'No' AND RETURN TO MENU MODE.	✓	'GAS' TARGET CONCENTRATION FLASHING AND '⌘' ICON DISPLAYED. USE ▲▼ TO CHANGE GAS CONCENTRATION AND '✓' TO START SPAN CALIBRATION.	✓	GAS NAME, CURRENT CONCENTRATION AND FLASHING '⌘' ICON DISPLAYED. APPLY SPAN GAS AND USE '✓' WHEN READING STABLE. IF OK 'PASS' & 'PurG' DISPLAYED (IF FAIL 'SPAN FAIL' DISPLAYED AND RETURNS TO MENU). REMOVE SPAN GAS. WHEN READING <50% OF SPAN POINT, COUNTDOWN BEGINS & UNIT RETURNS TO MENU MODE.
SEt rAn9	✓	BAR GRAPH INDICATING CURRENT RANGE, 'rAn9' DISPLAYED & CURRENT RANGE FLASHES. USE ▲▼ TO SELECT DIFFERENT RANGE	✓	IF RANGE IS CHANGED, 'CAL' DISPLAYED AND 'YES' FLASHING TO ASK IF YOU NOW WANT TO PERFORM CALIBRATION. USE '✓' TO PROCEED OR USE ▲▼ TO SELECT 'No'.	✓	IF RANGE IS CHANGED, 'ALrm' DISPLAYED AND 'YES' FLASHING TO ASK IF YOU NOW WANT TO MODIFY ALARM SETTINGS. USE '✓' TO PROCEED OR USE ▲▼ TO SELECT 'No' AND RETURN TO MENU MODE.	✓	UNIT RETURNS TO MENU MODE
ConF Inhb	✓	'Inhb' DISPLAYED WITH '⌘' ICON FLASHING. CURRENT INHIBIT mA VALUE FLASHES. USE ▲▼ TO SELECT NEW VALUE	✓	'timE' DISPLAYED WITH '⌘' ICON. FLASHING CURRENT INHIBIT TIMEOUT PERIOD (MINUTES) FLASHES. USE ▲▼ TO SET NEW TIMEOUT. (IF SET TO 0 OUTPUT IS PERMANENTLY INHIBITED)	✓	UNIT RETURNS TO MENU MODE		
SEt PASS	✓	'PASS' DISPLAYED WITH FIRST DIGIT PLACE ICON OF THE PASSCODE FLASHING. USE ▲ TO SELECT 1 ST DIGIT OF CURRENT PASSWORD. USE ▼ TO MOVE TO NEXT DIGIT AND SET REST OF PASSCODE.	✓	UNIT RETURNS TO MENU MODE				
CAL Int3 ²	✓	'Int' DISPLAYED WITH CURRENT CALIBRATION INTERVAL FLASHING. USE ▲▼ TO CHANGE INTERVAL.	✓	'duE' DISPLAYED AND 'No', 'LCd' OR 'ALL' FLASHING. USE ▲▼ TO SELECT REQUIRED CAL DUE WARNING OUTPUT.	✓	UNIT RETURNS TO MENU MODE		

bumP tEst	✓	PEAK READING DISPLAYED WITH OUTPUT INHIBITED  ICON AND PEAK STRING FLASHING. APPLY BUMP TEST GAS AND CHECK PEAK READING ON DISPLAY.	✓	CURRENT GAS CONCENTRATION DISPLAYED WITH OUTPUT INHIBITED  ICON FLASHING.	✓	UNIT RETURNS TO MENU MODE	
Forc Curr	✓	'Forc' DISPLAYED WITH  ICON. DEFAULT FORCE CURRENT '4.00' FLASHES. USE ▲▼ TO CHANGE TO REQUIRED mA LEVEL.	✓	UNIT TRANSMITS THE CURRENT IF YOU WANT TO EXIT FROM THIS MENU. USE ABORT FUNCTION			
Set ALrm	✓	'AL1', ICON DISPLAYED AND CURRENT ALARM LEVEL 1 CONCENTRATION FLASHES. USE ▲▼ TO CHANGE TO REQUIRED CONCENTRATION LEVEL.	✓	'AL1' DISPLAYED WITH 'NonE', 'rISE' OR 'FALL' FLASHING. USE ▲▼ TO SELECT REQUIRED ALARM ACTION.	✓	'AL2', ICON DISPLAYED AND CURRENT ALARM LEVEL 2 CONCENTRATION FLASHES. USE ▲▼ TO CHANGE TO REQUIRED CONCENTRATION LEVEL.	✓ 'AL2' DISPLAYED WITH 'NonE', 'rISE' OR 'FALL' FLASHING. USE ▲▼ TO SELECT REQUIRED ALARM ACTION AND USE '✓' TO RETURN TO MENU MODE.
Set rLY	✓	'rL1' DISPLAYED AND 'AL1', 'AL2', 'Inht' or 'FLt' FLASHES. USE ▲▼ TO CHANGE TO REQUIRED RELAY TARGET.	✓	'rL1' DISPLAYED AND 'dEEen' or 'Enr9' FLASHES. USE ▲▼ TO CHANGE TO REQUIRED RELAY ACTION.	✓	'Ri2' DISPLAYED AND 'AL1', 'AL2', 'Inht' or 'FLt' FLASHES. USE ▲▼ TO CHANGE TO REQUIRED RELAY TARGET.	✓ 'rL2' DISPLAYED AND 'dEEen' or 'Enr9' FLASHES. USE ▲▼ TO CHANGE TO REQUIRED RELAY ACTION.
	✓	'rL3' DISPLAYED AND 'AL1', 'AL2', 'Inht' or 'FLt' FLASHES. USE ▲▼ TO CHANGE TO REQUIRED RELAY TARGET.	✓	'rL3' DISPLAYED AND 'dEEen' or 'Enr9' FLASHES. USE ▲▼ TO CHANGE TO REQUIRED RELAY ACTION.	✓	UNIT RETURNS TO MENU MODE	
rLY OPr	✓	'rLY', 'ON' DISPLAYED AND CURRENT RELAY-ON TIME FLASHES. USE ▲▼ TO CHANGE TO REQUIRED RELAY-ON DELAY.	✓	'rLY', 'OFF' DISPLAYED AND CURRENT RELAY-OFF TIME FLASHES. USE ▲▼ TO CHANGE TO REQUIRED RELAY-OFF DELAY.	✓	'Ltch' DISPLAYED AND 'YES' or 'No' FLASHES. USE ▲▼ TO CHANGE TO REQUIRED LATCH OPTION.	✓ UNIT RETURNS TO MENU MODE
Set Loc	✓	'Loc' DISPLAYED WITH FIRST 4 CHARACTERS OF THE LOCATION STRING. USE ▼ TO CHANGE THE 1ST CHARACTER OF CURRENT LOCATION STRING. USE ▲ TO MOVE TO NEXT CHARACTER AND SET REST OF STRING. MAXIMUM 12 CHARACTERS CAN BE SET.	✓	'Loc' DISPLAYED NEW LOCATION STRING. THE STRING MOVES RIGHT-TO-LEFT TO SHOW WHOLE CHARACTERS TWICE. THEN UNIT AUTOMATICALLY RETURNS TO MENU MODE.			
tEm PUnit	✓	'tEmP' DISPLAYED WITH '°C' OR '°F' FLASHING. USE ▲▼ TO CHANGE TO REQUIRED TEMPERATURE UNIT.	✓	UNIT RETURNS TO MENU MODE			
tES tALrm	✓	'Forc' DISPLAYED and 'AL1' FLASHING TO SELECT TEST-REQUIRED ALARM. USE '✓' TO FORCE ALARM1.	✓	GAS NAME, CURRENT GAS CONCENTRATION DISPLAYED AND  ' AL ICON FLASHE.	✓	UNIT RETURNS TO MENU MODE	
9ult	✓	QUITS MENU MODE AND RETURNS TO MONITORING MODE					
▲▼	OK	▲▼	OK	▲▼	OK	▲▼	OK

¹ Refer to section 10.1 for detailed zero and span calibration procedures. Re-calibrate the detector if left un-powered for periods in excess of 24 hours.

² The calibration due warning counter is automatically reset after a successful calibration.

Table 12. Configuration Mode Operation

13.3 Sensor / Gas Selection

13.3.1 Sensor Selection

“Select Sensor” sets the identity of the type of mV sensor attached to the XCD RFD when it does not detect the sensor type automatically.

The available mV sensors:

Cb-2	Sensepoint HT 20%LEL remote
Cb-3	Sensepoint HT 100%LEL remote
Cb-4	Sensepoint 100%LEL remote
Cb-5*	Flammable CAT 0-100%LEL remote
Ir-5*	Carbon Dioxide IR 0-2%VOL only remote
Ir-7	Methane IR 0-100%LEL remote
Ir-8*	Propane IR 0-100%LEL remote

Selecting ‘✓’ will move the operator to the Select Sensor screen. The first screen displays the currently configured sensor. To select a new mV sensor like remote type sensors (Ir-7, Cb-3 and Cb-4), use ‘▲▼’ to move through the list, and then use ‘✓’ to make the selection or discard the selection and return to menu mode by using abort function. If type of sensor is changed, calibration prompt will appear to ask if you want to perform calibration.

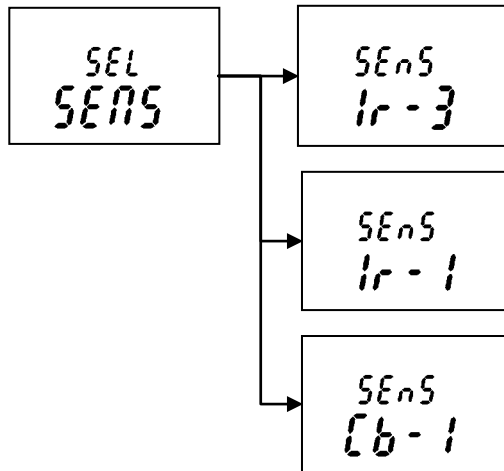

Diagram 15: Sensor Selection

13.3.2 Gas Selection

Use “SEL gAS” to set the target gas for sensors capable of detecting multiple gases.

The available gases:

Sensor type	Gas type	Gas Name displayed
Cb-3	Str 1 to Str 8	FLM
Cb-4	Str 1 to Str 8	FLM
Cb-5*	Str 1 to Str 8	FLM
Ir-5*	CO2	CO2
Ir-7	Methane	mEt
Ir-8*	Propane	ProP

*Contact Honeywell Analytics for availability

Gas selection is dependent on the type of sensor attached to the XCD RFD. If Ir-7 sensor is attached, then a user can only select 'mEt' gas respectively. But when Cb-3/Cb-4 sensor is attached to the XCD RFD, a user can select the gas from Str1 (1*) to Str8 (8*). For more information on star rating, please refer to section 19.2.

The current configuration of the XCD RFD is displayed and by using the '✓' switch to enter "SEL gAS" menu. To select a flammable gas, use '▲▼' to move through the list, and then use '✓' to make the selection or abort function to discard the selection and return to menu mode.

If type of gas is changed, calibration prompt will appear to ask if you want to perform calibration.

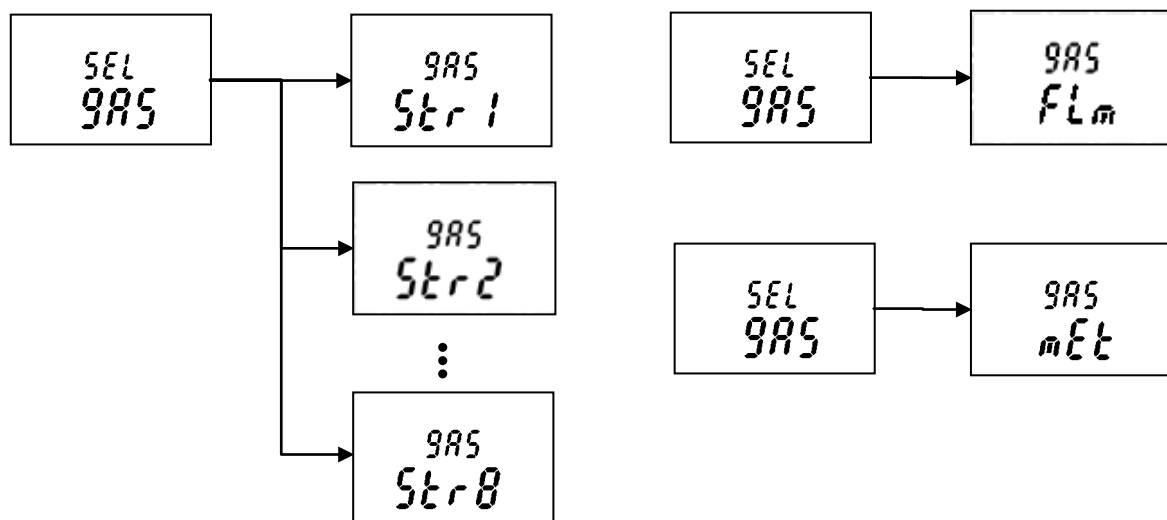

Diagram 16: Gas Selection

CAUTION

The 4-20mA analogue output signal will remain INHIBITED at 2mA (default setting) while the XCD RFD remains in Configuration Mode. However, the ALARM and FAULT RELAYS remain Active.







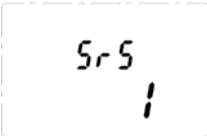

Changing the configuration of the Sensor Type or the Gas Star Rating for catalytic sensors may result in temporary activation of the ALARM or FAULT RELAYS. Should this occur, then recalibrating the sensor will return the XCD RFD to normal condition and reset the relays.

As a precaution, please take necessary action to manually inhibit any external actuator or alarm devices that are connected to the XCD RFD Alarm/Fault Relays to prevent unnecessary activation during commissioning or reconfiguration of the XCD RFD gas detector.

13.4 Review Mode

The instrument will enter **Review mode** when the “Enter” switch is activated with the Magnetic Wand and held for around one second.

Names, displays and descriptions for each review item in Review Mode are shown in the following table.

Item name	Display	Description
Software version		S/W version of transmitter
SRS version		S/W version of SRS (watch dog)
EEP version		EEPROM parameter version
Gas		Gas type
Measuring range		A user selected measuring range
Calibration level		Calibration gas level
Calibration due		Estimated time to next calibration
Alarm 1		Alarm settings for Alarm 1
Alarm 2		Alarm settings for Alarm 2





Location		Location in which the transmitter is installed
Power		Power voltage*
Temperature		Internal Transmitter temperature*
Peak conc.		Maximum concentration detected up to now
Test Result		There is no fault detected.

Table 13: Transmitter menu descriptions

Note:

**Power voltage and internal transmitter temperature may be different from actual value due to measuring accuracy and internal heating components.*

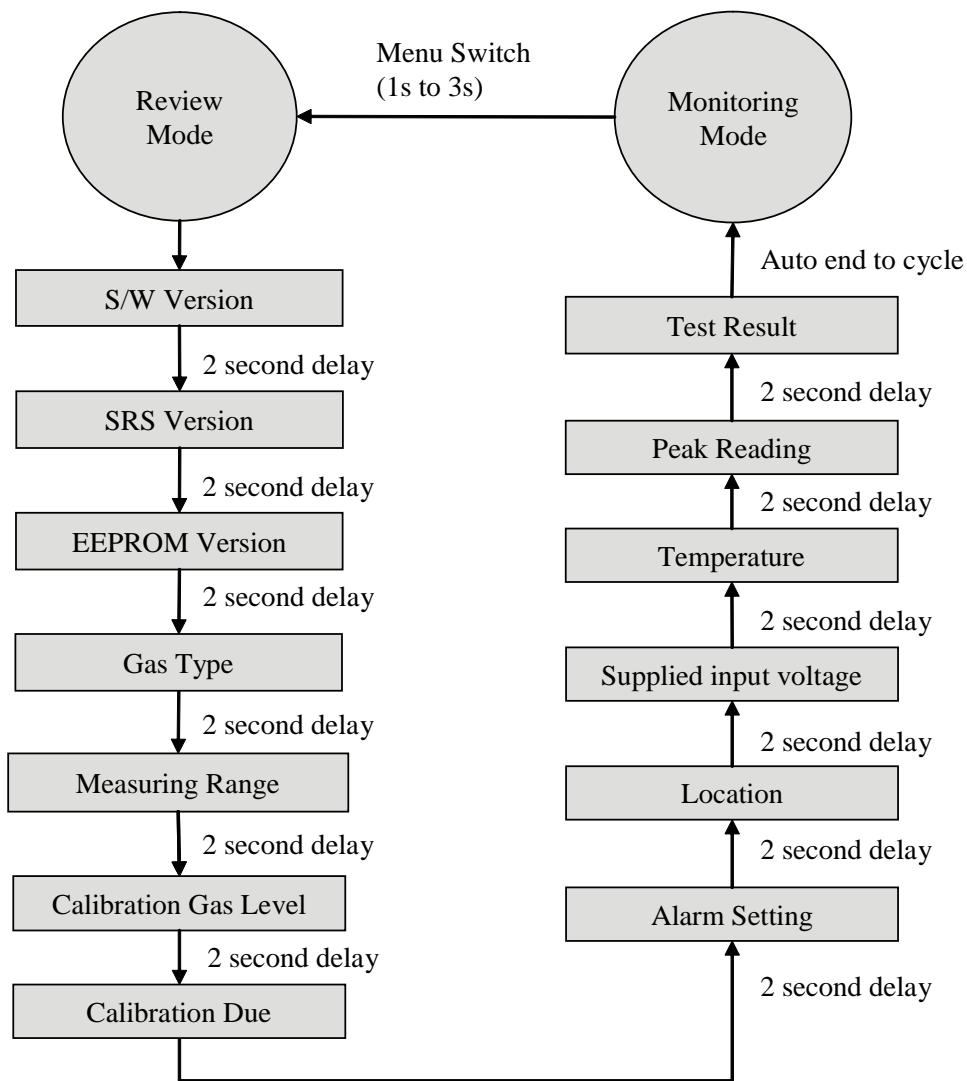

Diagram 17: Review Mode

14 General specification

Sensepoint XCD Transmitter														
Use		3-wire, 4-20mA, gas detector transmitter for use with remotely mounted flammable gas detectors.												
Electrical														
Input Voltage Range:		16 to 32Vdc (24Vdc nominal)												
Max Power Consumption:		Max 5 Watts. at 24Vdc (see section 2 regarding maximum in rush current)												
Current output		4-20mA (Source or Sink)												
≥0.0<1.0 mA		Fault (refer to table 5 section 12.3 for further details).												
4.0 mA to 20.0 mA		Normal gas measurement												
2.0 mA or 4.0 mA		Inhibit (during configuration/user settings)												
22.0 mA		Maximum over range												
Terminals		15 x screw terminals suitable for wire diameter 0.5mm ² to 2.5mm ² (20AWG to 13AWG).												
Relays		3 x 5A@250VAC. Selectable normally open or normally closed (switch) and energized/de-energized (programmable).												
Communication		RS485, Modbus RTU(Pending)												
Construction														
Material		Epoxy painted aluminium alloy or 316 Stainless Steel												
Weight		Aluminium alloy: 1.7kg, 316 Stainless Steel: 3.7kg												
Mounting		Pole or wall mounting												
Entries		2 x M20 (for ATEX/IECEX/AP Approval) , M25 entry for remote cable or local sensor												
Detectable Gases & Performance (See notes below)														
Gas	Selectable Full Scale Range	Default Range	Steps	Selectable Cal Gas Range	Default Cal Point	Response Time (T60) Secs	Response Time (T90) Secs	Accuracy	Operating Temperature		Default Alarm Points			
									Min	Max	A1	A2		
Sensepoint Standard Temperature Sensor														
Flammable 1 to 8*	20 to 100%LEL	100%LEL	10%LEL	25 to 95% of selected full scale range	50%LEL		<25	<+/- 1.5%LEL	-55°C / -67°F	80°C / 176°F	20%LEL▲	40%LEL▲		
Sensepoint High Temperature Sensor														
Flammable 1 to 8*	20%LEL	20%LEL	n/a		10%LEL		<25	<+/- 1.5%LEL	-55°C / -67°F	150°C / 302°F	10%LEL▲	15%LEL▲		
Flammable 1 to 8*	20 to 100%LEL	100%LEL	10%LEL	30 to 70% of selected full scale range	50%LEL	<6	<10	<+/- 1.5%LEL	-55°C / -67°F	150°C / 302°F	20%LEL▲	40%LEL▲		
Plug-in Sensepoint XCD Catalytic Bead Sensors														
Flammable 1 to 8**	20 to 100%LEL	100%LEL	10%LEL		50%LEL		<25	<+/-1.5%LEL	-20°C / -4°F	55°C / 131°F	20%LEL▲	40%LEL▲		
Plug-in Sensepoint XCD Infrared Sensors														
Methane	20 to 100%LEL	100%LEL	10%LEL	50%LEL		<40	<+/-1.5%LEL	-20°C / -4°F	50°C / 122°F	20%LEL▲	40%LEL▲			
Propane*	20 to 100%LEL	100%LEL	10%LEL	50%LEL		<40	<+/-1.5%LEL	-20°C / -4°F	50°C / 122°F	20%LEL▲	40%LEL▲			
Carbon Dioxide*	2.00%Vol.	2.00%Vol.	n/a	1.00%Vol.		<40	<+/-0.04%Vol.	-20°C / -4°F	50°C / 122°F	0.40%V/V▲	0.80%V/V▲			
*Contact Honeywell Analytics for availability														
▲ - Rising Alarm ▼ - Falling Alarm														
NOTES														
Performance figures are taken at 20-25°C;														
1. measured using a sample humidity of 50%RH, applicable between 10 and 90% of full scale,														
2. measured using test units calibrated at 50% of full scale,														
3. measured at 1000cc/min for Methane CAT, 500cc/min for Methane IR with calibration cup (S3KCAL).														
Response time (T90) may increase when operating in lower or higher temperature conditions or when gas is introduced with the Weather Protection accessory (SPXCDWP) fitted. Methane IR sensor is calibrated and linearised only for Methane. Should it be exposed to other HC then non linear response is expected. For linearised operation other than Methane contact HA for alternate parts. Methane IR is calibrated at the factory 50%LEL Methane (2.5%Vol). This calibration enables 100% functional test prior to dispatch. This calibration does not remove need for calibration & test as part of commissioning at site. For gases other than Methane the unit has to be calibrated at site using target gas. Data represents typical values, and system conditioning may be required to achieve stated result. Contact HA for details.														
* Extended operating temperature range of -40°C to +65°C (-40°F to +149°F) for all sensor except for IR, with an accuracy of +/- 30% of applied gas from -20°C to -40°C (-4°F to -40°F) and +55°C to +65°C (+131°F to +149°F). Long term operation at this range may cause decline in sensor performance.														
Contact Honeywell Analytics for any additional data or details.														
Certification														
China	GB Ex d IIC T4 GB3836.1&2 -2000, PA, (CCCF – Pending)													
Korea	KTL Ex d IIC T6 (-40°C to +65°C)													
European	ATEX Ex II 2 GD Ex d IIC Gb T6(Ta -40°C to +65°C) Ex tb IIIC T85°C Db IP66													
International	IEC Ex II 2 GD Ex d IIC Gb T6(Ta -40°C to +65°C) Ex tb IIIC T85°C Db IP66													
CE	EN50270:2006 EN6100-6-4:2007													
Environmental														
IP Rating		IP66 in accordance with EN60529:1992												
Operating Temperature		-40°C to +65°C/ -40°F to +149°F, (IR: -20°C to +50°C/ -4°F to +122°F). Note: The detector display may become illegible at temperatures below -20°C, but the detector continues its gas monitoring function. The display is not damaged and recovers when the temperature rises back above -20 °C.												
Operating Humidity		Continuous 20-90%RH (non condensing), Intermittent 10-99%RH (non condensing)												
Operating Pressure		90-110kPa												
Storage Conditions		-25°C to +65°C (-13°F to +149°F)												

15 Ordering information

Part number	Description
Sensepoint XCD RFD transmitter (ATEX/IECEX/AP*, LM25 and M20 Entry)	
SPXCDALMRFD	ATEX/IECEX/AP* approved SP XCD RFD Transmitter with LM25
Sensepoint XCD RFD transmitter (ATEX/IECEX/AP*, 316SS and M20 Entry)	
SPXCDASMRFD	ATEX, IECEX approved SP XCD RFD Transmitter with 316SS
Replacement Sensepoint XCD sensor cartridge	
SPXCDXSFXSS**	Flammable CAT 0-100%LEL (20,0 to 100.0%LEL)
SPXCDXSRXSS	Methane IR 0-100%LEL (20,0 to 100.0%LEL)
SPXCDXSPXSS**	Propane IR 0-100%LEL (20,0 to 100.0%LEL)
SPXCDXSB1SS**	Carbon Dioxide IR 0-2.00%VOL only
Remote Flammable Sensor (XCD Sensor Cartridge + Socket Housing)	
SPXCDXSRFXSS**	Flammable CAT 0-100%LEL (20,0 to 100.0%LEL)
SPXCDXSRRXSS	Methane IR 0-100%LEL (20,0 to 100.0%LEL)
SPXCDXSRPXSS**	Propane IR 0-100%LEL (20,0 to 100.0%LEL)
SPXCDXSRBXSS**	Carbon Dioxide IR 0-2.00%VOL only
Replacement Sensepoint Sensor	
2106B1200	Standard LEL Version , -55°C to +80°C, M20 version, ATEX Certification
2106B1201	Standard LEL Version , -55°C to +80°C, M25 version, ATEX Certification
2106B1204	Standard LEL Version , -55°C to +80°C, 3/4 NPT version, ATEX Certification
2106B2310	High temperature LEL Version, -40°C to +150°C, M20 version, ATEX Certification
2106B2311	High temperature LEL Version, -40°C to +150°C, M25 version, ATEX Certification
2106B2312	High temperature LEL Version, -40°C to +150°C, 3/4 NPT version, ATEX Certification
Sensepoint XCD Accessories	
S3KCAL	Calibration cap
SPXCDCC	Collecting cone for use with lighter than air gases
SPXCDDMK	Duct mounting kit
SPXCMTBR	Pipe Mounting bracket (inc. fixings and hex wrench set)
SPXCSDP	Sunshade / Deluge Protection
SPXCDHMRFEN	Hard Copy Manual in English
Sensepoint Accessories	
2052D0001	High Temperature Junction Box
02000-A-1645	Calibration gas flow housing
00780-A-0100	Junction box (std)
2106M0502	Sensepoint Technical Handbook in English
Sensepoint XCD Spares	
SPXCDDMF	ATEX/IECEX & AP approved SP XCD FL/IR Transmitter with LM25, M20 Entry
SPXCDTMF	ATEX/IECEX & AP approved SP XCD FL/IR Transmitter with SS316, M20 Entry
SPXCDM20P	M20 Plug

SPXCDMANCD	Instruction manual CD
SPXCDMAG	Magnet
SPXCDSRLS	Sensor Retainer with locking screw
SPXCDAKS	Allen key for stopper
SPXCDHWES	Hex wrench for earth screw
SPXCDEBS	Earth Bracket and Screws
Sensepoint Spares	
00780-F-0018	Stainless steel filter, High temperature LEL Version, -40°C to +150°C
00780-C-0038	Filter Housing, High temperature LEL Version, -40°C to +150°C
* AP approvals include GB & PA for China and KTL for Korea. **Contact Honeywell Analytics for availability.	

16 Warranty statement

All products are designed and manufactured to the latest internationally recognized standards by Honeywell Analytics under a Quality Management system that is certified to ISO 9001. As such Honeywell Analytics warrants its products against defective parts and workmanship and will repair or (at its option) replace any instruments which are or may become defective under proper use within 12 months from date of commissioning by an approved Honeywell Analytics representative or 18 months from date of shipment from Honeywell Analytics, whichever is the sooner. This warranty does not cover disposable batteries or damage caused by accident, abuse, abnormal operating conditions or poisoning of sensor.

Defective goods must be returned to Honeywell Analytics premises accompanied by a detailed description of any issue. Where return of goods is not practicable Honeywell Analytics reserves the right to charge for any site attendance where any fault is not found with the equipment. Honeywell Analytics shall not be liable for any loss or damage whatsoever or howsoever occasioned which may be a direct or indirect result of the use or operation of the Contract Goods by the Buyer or any Party.

This warranty covers instrument and parts sold to the Buyer only by authorized distributors, dealers and representatives as appointed by Honeywell Analytics. The warranties set out in this clause are not pro rata, i.e. the initial warranty period is not extended by virtue of any works carried out there under.

In no event will Honeywell Analytics be liable for any incidental damages, consequential damages, special damages, punitive damages, statutory damages, indirect damages, loss of profits, loss of revenues, or loss of use, even if informed of the possibility of such damages. Honeywell Analytic's liability for any claims arising out of or related to this product will in no case exceed the order value. To the extent permitted by applicable law, these limitations and exclusions will apply regardless of whether liability arises from breach of contract, warranty, tort (including but not limited to negligence), by operation of law, or otherwise.

17 Installation Drawing

17.1 Mechanical Installation Drawing

3001G0453

SHT. 1

THIS DOCUMENT HAS BEEN GENERATED USING AutoCAD AND MUST ONLY BE UPDATED BY C.A.D.

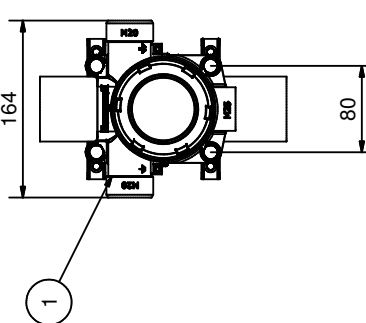
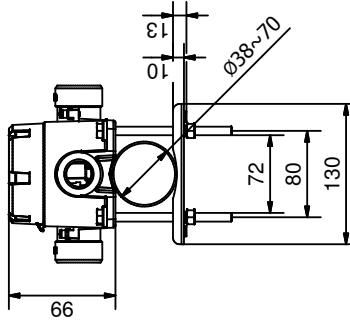

Vertical Pipe Mounted

164
80
66
72
80
130
Ø38~70

SCALE: SA 07-Dec-09

DRN: SA

TITLE: Sensepoint XCD RFD Installation Drawing

3001G0453

SHT. 1 OF 4

Horizontal Pipe Mounted

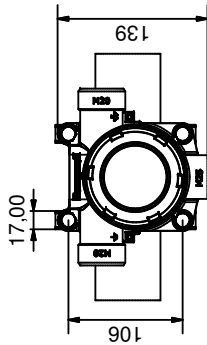
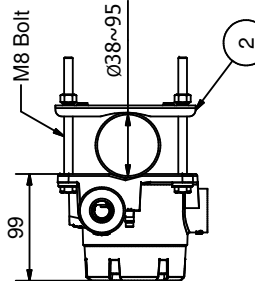
17.00
106
139
99
Ø38~95
M8 Bolt
2

Wall Mounted

80
106
99
4 - M8 Bolt
4 - Ø8.50 HOLE

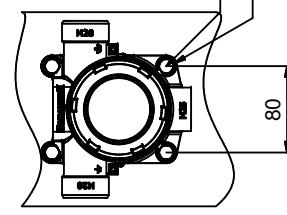
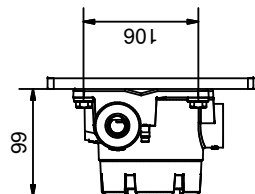
THIS ITEM FORMS PART OF A CERTIFIED PRODUCT. NO MODIFICATION PERMITTED WITHOUT REFERENCE TO CERTIFICATION DEPARTMENT.

I. SPECIFICATION

1. SIZE: 164 X 217 X 99

2. MATERIAL

A. TRANSMITTER: LM25 / 316SS

B. MOUNTING BRACKET: 316SS

3. WEIGHT: 2kg / 4.5kg

A. TRANSMITTER(LM25): 1.8kg

B. TRANSMITTER(316SS): 4.3kg

C. MOUNTING BRACKET: 0.2kg

II. HAZARDOUS CERTIFICATION

1. ATEX

II 2 GD

Ex d IIC Gb T6(Ta -40 °C to +65 °C)

Ex tb IIIC T85 °C Db IP66

Baseefa08ATEX0222

2. KTL

Ex d IIC T6, 16~32Volts DC, Pmax=5W

Tamb. -40 °C to +65 °C

3. GB, PA

III. ITEM LIST

1. XCD RFD TRANSMITTER

2. PIPE MOUNTING BRACKET

FINISH

ALL DIMENSIONS IN MILLIMETRES UNLESS OTHERWISE STATED. AND APPLY AFTER PLATING

THIS DRAWING IS TO BS 8888

REMOVE ALL BURRS AND SHARP EDGES

SURFACE TEXTURE VALUES ARE IN µm Ra AND TO BS 1134

TOLEANCES TO BE AS SPECIFIED BELOW UNLESS OTHERWISE STATED.

DIMS.

2 DP ± 0.1 mm

1 DP ± 0.25 mm

NONE ± 0.4 mm

ANGULAR ± 1/2 °

HOLES.

Ø 0 to 8 + 0.08

Ø 8 to 14 + 0.0

Ø 14 to 25 + 0.12

THIS DRAWING IS CONFIDENTIAL. IT IS THE PROPERTY OF HONEYWELL ANALYTICS LTD AND MUST NOT BE REPRODUCED EITHER WHOLLY OR PARTLY. ALL RIGHTS IN RESPECT OF PATENTS, DESIGNS AND COPYRIGHT ARE RESERVED.

17.2 Electronic Connection Drawing

3001G0453 SH1. 3

THIS DOCUMENT HAS BEEN GENERATED USING AutoCAD AND MUST ONLY BE UPDATED BY C.A.D.

Transmitter & Detector (Sensor)

3 Wire Flammable / IR Sensor

Terminal Module Connections

Terminal Number	Marking	Connection	Description
1	24V	+ VE Supply(18-32VDC)	Controller Connections
2	0V	-VE Supply(0VDC)	
3	4~20mA	Current Output Signal	
4	COM	Common	MODBUS RTU, RS485(Pending)
5	TxD	MODBUS B (+)	
6	RxD	MODBUS A (-)	Programmable Relay 1 (Default A1)
7	RLY1/NC	Normally Closed	
8	RLY1/COM	Common	Programmable Relay 2 (Default A2)
9	RLY1/NO	Normally Open	
10	RLY2/NC	Normally Closed	Programmable Relay 3 (Default Fault)
11	RLY2/COM	Common	
12	RLY2/NO	Normally Open	RFD Sensor Connection
13	RLY3/NC	Normally Closed	
14	RLY3/COM	Common	
15	RLY3/NO	Normally Open	
16	+VE	Sensitive (Sensor Brown Wire)	
17	-VE	Non-Sensitive (Sensor Blue Wire)	
18	01	Signal (Sensor White Wire)	

NOTES:

- REFER TO INSTRUCTION MANUAL FOR TECHNICAL DETAILS.
- XCD OPERATING VOLTAGE 18~32Volts DC, 5W(Max)
- 4-20 mA LOOP RESISTANCE TO BE < 300 ohms
- POWER SUPPLY LOOP RESISTANCE TO BE < 12 ohm
- NO TWO 'EARTH POINTS' SHOULD BE CONNECTED VIA SCREEN AND/OR CONDUIT SO AS TO AVOID 'GROUND LOOPS'.
- MULTIPLE 'EARTH POINTS' ARE NOT ALLOWED.
- 'GJ POINTS' (CONTINUITY OF SCREEN) MAY BE ACHIEVED USING APPROPRIATE GLANDS/CABLE OR CONDUIT; INTERNAL AND EXTERNAL 'EARTH POINTS' IN THE TRANSMITTER ARE PROVIDED.

ALL DIMENSIONS IN MILLIMETRES UNLESS OTHERWISE STATED. THIS DRAWING IS TO BS 8888 AND APPLY AFTER PLATING.

REMOVE ALL BURRS AND SHARP EDGES

SURFACE TEXTURE VALUES ARE IN um Ra AND TO BS 1134

FINISH

MATERIAL	SCALE	DRAWN	SA
	NTS		07-Dec-09

TITLE

Sensepoint XCD RFD Installation Drawing

3001G0453

SH1. 3 OF 4

17.4 Collecting Cone Drawing

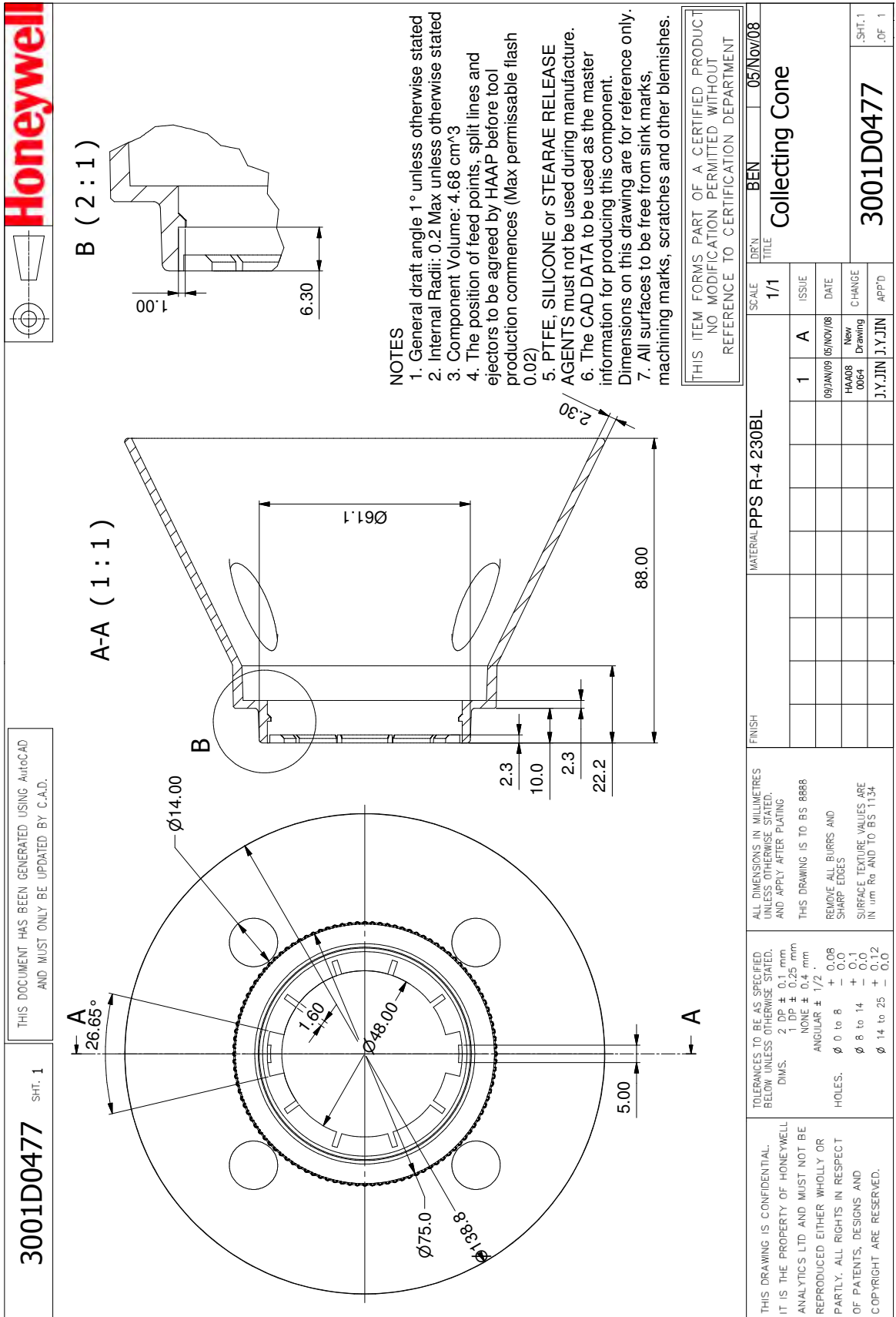

THIS DOCUMENT HAS BEEN GENERATED USING AutoCAD AND MUST ONLY BE UPDATED BY C.A.D.

3001D0477
SHT. 1

B (2 : 1)

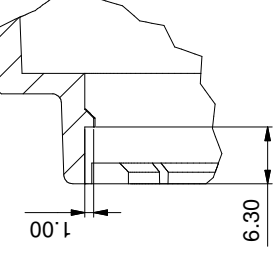

A-A (1 : 1)

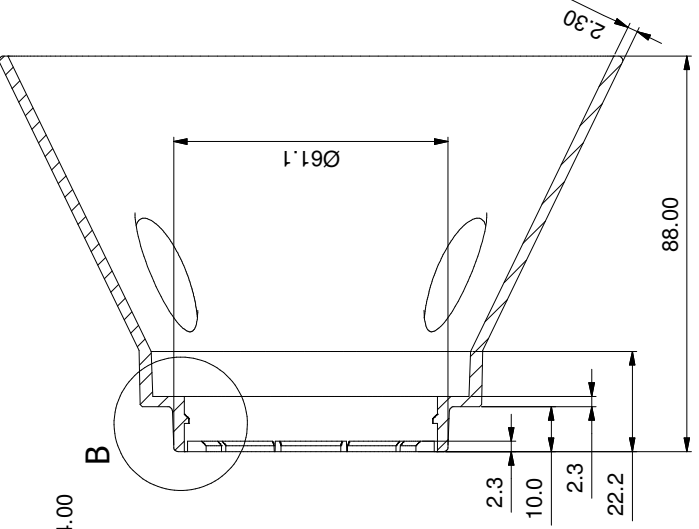

NOTES

1. General draft angle 1° unless otherwise stated
2. Internal Radii: 0.2 Max unless otherwise stated
3. Component Volume: 4.68 cm³
4. The position of feed points, split lines and ejectors to be agreed by HAAP before tool production commences (Max permissible flash 0.02)
5. PTFE, SILICONE or STEARAE RELEASE AGENTS must not be used during manufacture.
6. The CAD DATA to be used as the master information for producing this component.
7. All surfaces to be free from sink marks, machining marks, scratches and other blemishes.

THIS ITEM FORMS PART OF A CERTIFIED PRODUCT NO MODIFICATION PERMITTED WITHOUT REFERENCE TO CERTIFICATION DEPARTMENT

MATERIAL		PPS R-4 230BL		FINISH		ALL DIMENSIONS IN MILLIMETRES UNLESS OTHERWISE STATED. AND APPLY AFTER PLATING. THIS DRAWING IS TO BS 8888 REMOVE ALL BURRS AND SHARP EDGES SURFACE TEXTURE VALUES ARE IN um Ra AND TO BS 1134.		TOLERANCES TO BE AS SPECIFIED BELOW UNLESS OTHERWISE STATED. DIMS. 2 DP ± 0.1 mm 1 DP ± 0.25 mm NONE ± 0.4 mm ANGULAR ± 1/2 ° HOLES. Ø 0 to 8 + 0.08 - 0.0 Ø 8 to 14 + 0.0 - 0.0 Ø 14 to 25 + 0.12 - 0.0		THIS DRAWING IS CONFIDENTIAL. IT IS THE PROPERTY OF HONEYWELL ANALYTICS LTD AND MUST NOT BE REPRODUCED EITHER WHOLLY OR PARTLY. ALL RIGHTS IN RESPECT OF PATENTS, DESIGNS AND COPYRIGHT ARE RESERVED.		
SCALE	1/1	DRAWN	BEN	TITLE	Collecting Cone	DATE	09/JAN/09	ISSUE	1	DATE	05/NOV/08	.SHT. 1 .OF 1
CHANGE		HAAP08	0064	3001D0477		NEW		J.Y.JIN	J.Y.JIN			

17.5 Mounting Bolt Assy Drawing

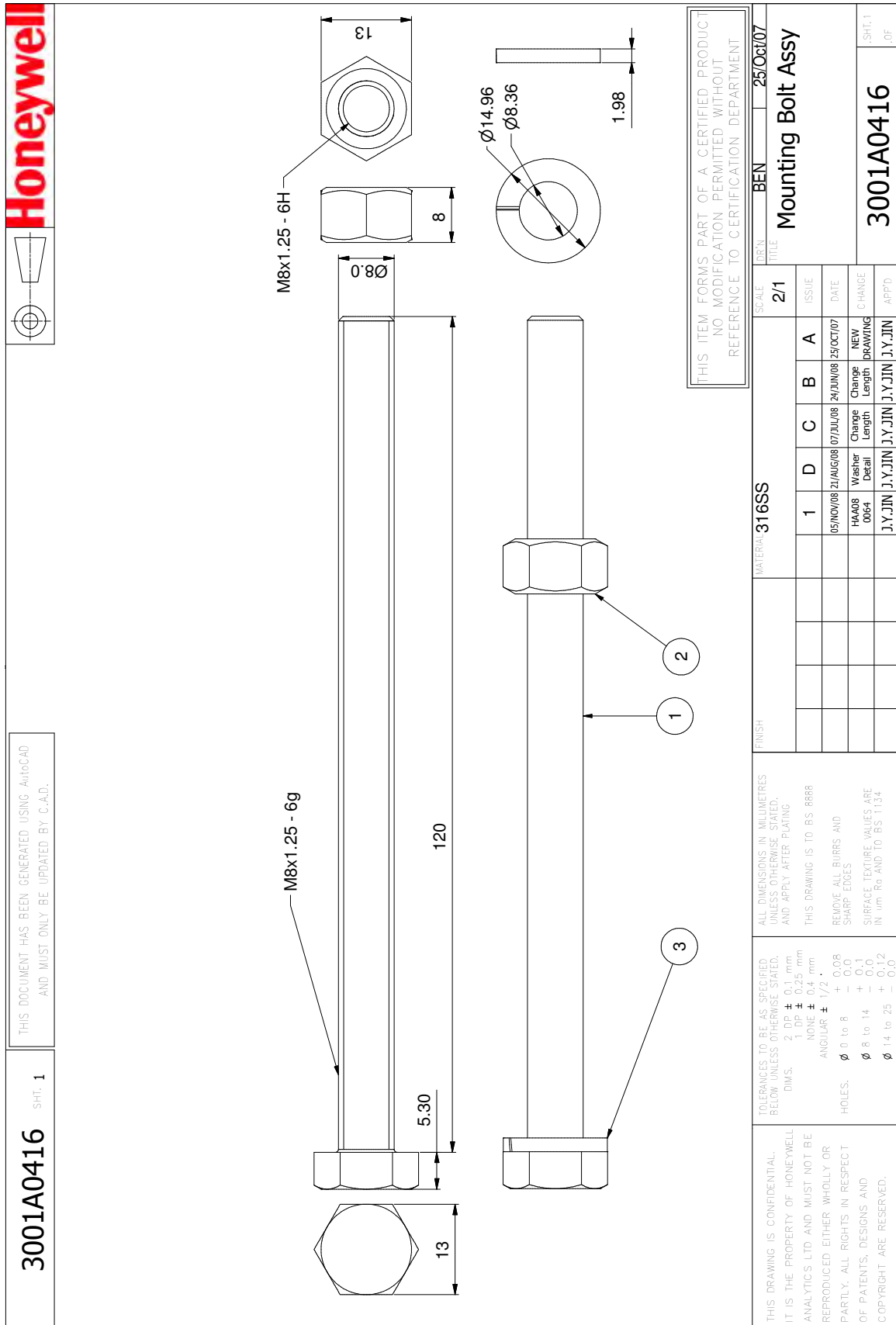

17.6 Mounting Bracket Drawing

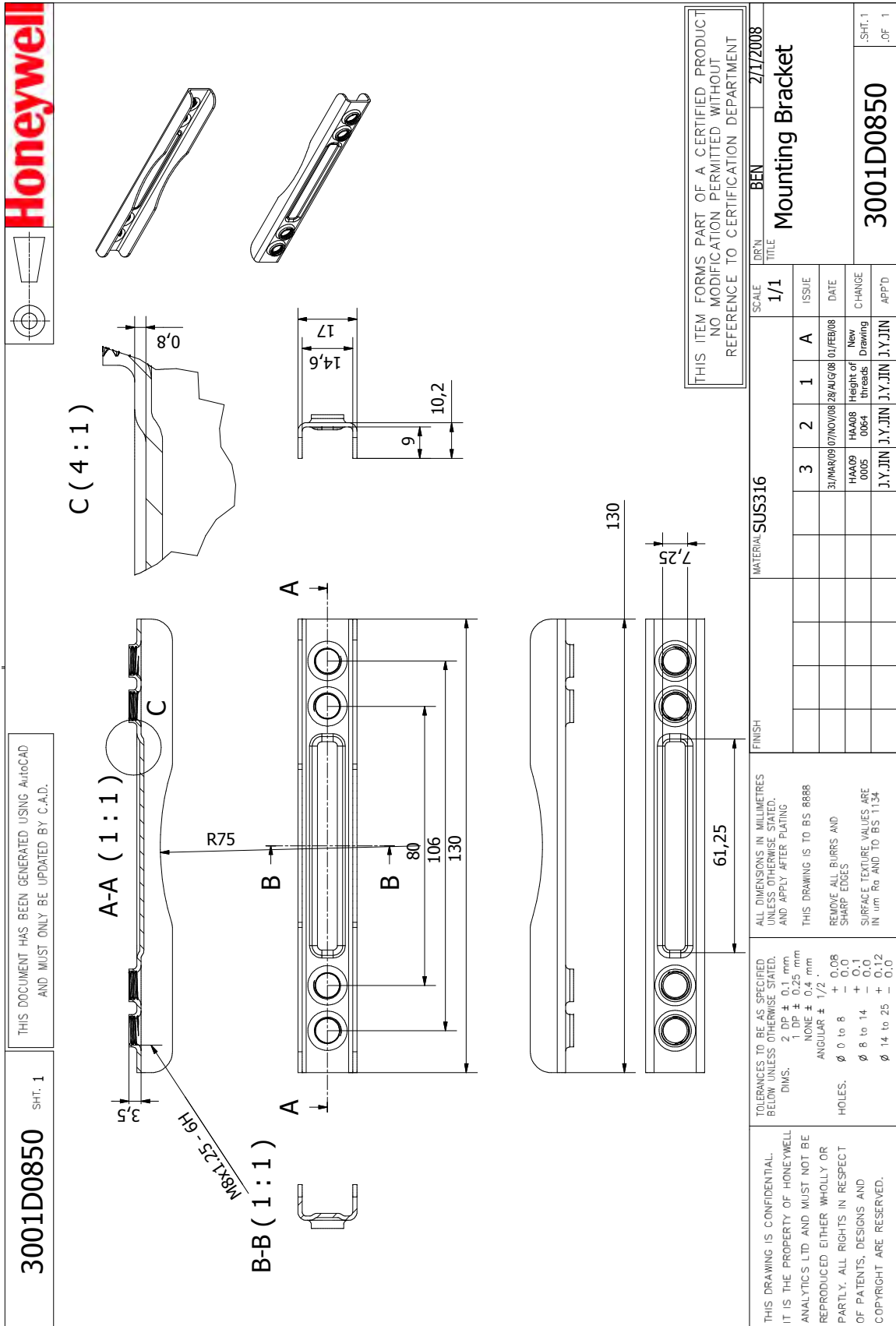

17.7 Sensepoint XCD RFD Sensor

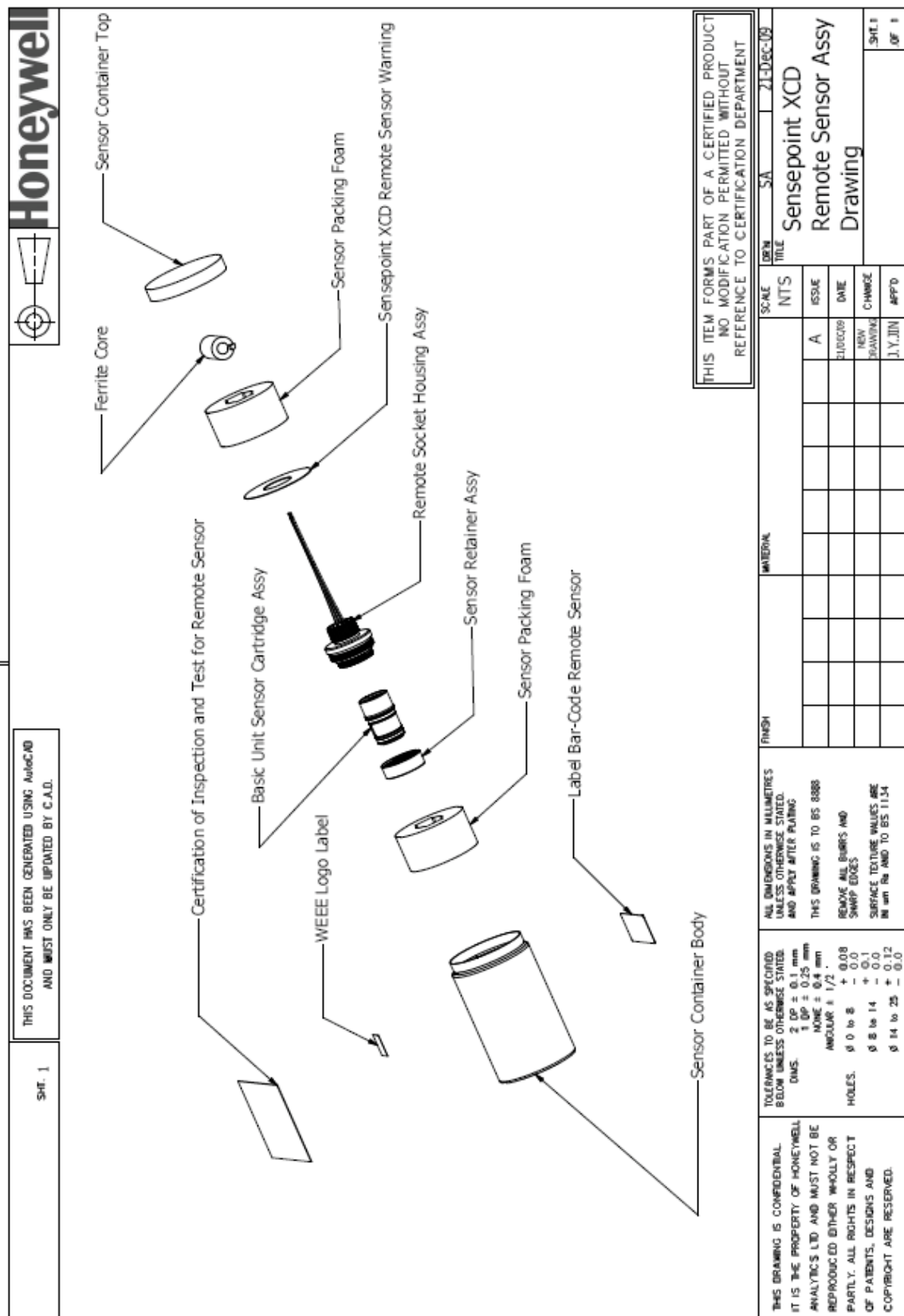

THIS DOCUMENT HAS BEEN GENERATED USING AutoCAD AND MUST ONLY BE UPDATED BY C.A.D.

SHR. 1

THIS ITEM FORMS PART OF A CERTIFIED PRODUCT. NO MODIFICATION PERMITTED WITHOUT REFERENCE TO CERTIFICATION DEPARTMENT.

SCALE	DATE	BY	SA	21 DEC 09
NTS	TITLE	Sensepoint XCD Remote Sensor Assy Drawing		
A	ISSUE			
	DATE			
	CHANGED BY			
	APPROVED			

MATERIAL	FINISH	TOLERANCES TO BE AS SPECIFIED BELOW UNLESS OTHERWISE STATED.	THIS DRAWING IS TO BS 8888	REMOVE ALL BURRS AND SHARP EDGES	SURFACE TEXTURE VALUES ARE IN µm Ra AND TO BS 1134
		2 DP ± 0.1 mm			
		1 DP ± 0.25 mm			
		FAIR ± 0.4 mm			
		ANGULAR ± 1/2 °			
		HOLE: Ø 0 to 8 + 0.08			
		Ø 8 to 14 + 0.1			
		Ø 14 to 25 + 0.2			

THIS DRAWING IS CONFIDENTIAL. IT IS THE PROPERTY OF HONEYWELL ANALYTICS LTD AND MUST NOT BE REPRODUCED EITHER WHOLLY OR PARTLY. ALL RIGHTS IN RESPECT OF PATENTS, DESIGNS AND COPYRIGHT ARE RESERVED.

18 Certification

18.1 China GB Ex and PA

China GB Ex (Chinese Version):



防 爆 合 格 证

证号: GYJ081072X

由 **霍尼韦尔探测器亚太有限公司** 制造的产品:
(地址: 508 Korea Science Valley(H) 187-10 Guro-dong, Guro-Gu Seoul, 152-050, Korea)

名 称 **可燃气体探测器**

型号规格 **Sensepoint XCD**

防爆标志 **Ex d IIC T4**

产品标准 /

图样编号 **3001EG026、3001EG027**

经图样及技术文件的审查和样品检验, 确认上述产品符合 **GB 3836.1-2000、GB 3836.2-2000** 标准, 特颁发此证。有效期自颁发日期起 **伍** 年内有效。

备注 产品使用安全注意事项见防爆合格证附件1。

站长 

国家级仪器仪表防爆安全监督检验站

颁发日期 **二〇〇八** 年 **七** 月 **十五** 日

本证书仅对与认可文件和样品一致的产品有效。

地址: 上海市灵石路103号	网址: www.nepsi.org.cn	电话: 0086 21 64568180
邮编: 200233	Email: info@nepsi.org.cn	传真: 0086 21 64544580

China GB Ex (English Version):



China PA Certification:

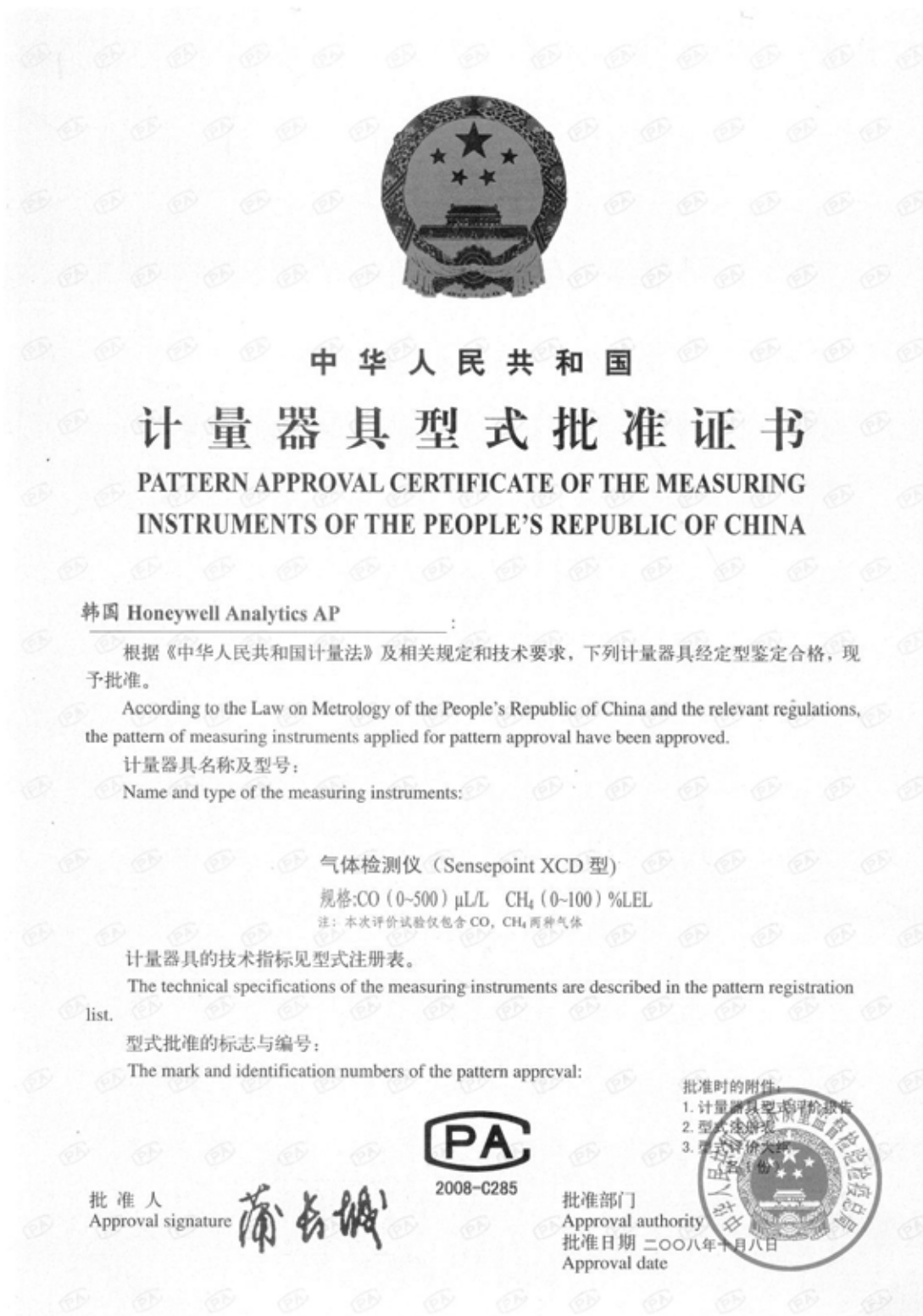

中华人民共和国

计量器具型式批准证书

PATTERN APPROVAL CERTIFICATE OF THE MEASURING INSTRUMENTS OF THE PEOPLE'S REPUBLIC OF CHINA

韩国 Honeywell Analytics AP _____ :

根据《中华人民共和国计量法》及相关规定和技术要求,下列计量器具经定型鉴定合格,现予批准。

According to the Law on Metrology of the People's Republic of China and the relevant regulations, the pattern of measuring instruments applied for pattern approval have been approved.

计量器具名称及型号:

Name and type of the measuring instruments:

气体检测仪 (Sensepoint XCD 型)

规格:CO (0-500) μ L/L CH₄ (0-100) %LEL

注:本次评价试验仅包含 CO, CH₄ 两种气体

计量器具的技术指标见型式注册表。

The technical specifications of the measuring instruments are described in the pattern registration list.

型式批准的标志与编号:

The mark and identification numbers of the pattern approval:

批准人
Approval signature



2008-C285

批准部门
Approval authority

批准日期 二〇〇八年十月八日
Approval date

批准时的附件:

1. 计量器具型式评价报告
2. 型式注册表
3. 型式评价大纲



18.2 Korea KTL



18.3 European ATEX

ATEX For Transmitter:

Certificate Number
Baseefa08ATEX0222



Issued 31 October 2008
Page 1 of 2

- 1 EC - TYPE EXAMINATION CERTIFICATE**
- 2 Equipment or Protective System Intended for use in Potentially Explosive Atmospheres
Directive 94/9/EC**
- 3 EC - Type Examination Certificate Number: Baseefa08ATEX0222**
- 4 Equipment or Protective System: A Type XCD Transmitter**
- 5 Manufacturer: Honeywell Analytics**
- 6 Address: 405 Barclay Boulevard, Lincolnshire, IL 60069, USA.**
- 7 This equipment or protective system and any acceptable variation thereto is specified in the schedule to this certificate and the documents therein referred to.**
- 8 Baseefa, Notified Body number 1180, in accordance with Article 9 of the Council Directive 94/9/EC of 23 March 1994, certifies that this equipment or protective system has been found to comply with the Essential Health and Safety Requirements relating to the design and construction of equipment and protective systems intended for use in potentially explosive atmospheres given in Annex II to the Directive.**
- The examination and test results are recorded in confidential Report No. **GB/BAS/ExTR08.0149/00**
- 9 Compliance with the Essential Health and Safety Requirements has been assured by compliance with:**
IEC60079-0: 2007 EN60079-1: 2007 EN 61241-1: 2006
- except in respect of those requirements listed at item 18 of the Schedule.
- 10 If the sign "X" is placed after the certificate number, it indicates that the equipment or protective system is subject to special conditions for safe use specified in the schedule to this certificate.**
- 11 This EC - TYPE EXAMINATION CERTIFICATE relates only to the design and construction of the specified equipment or protective system. Further requirements of the Directive apply to the manufacturing process and supply of this equipment or protective system. These are not covered by this certificate.**
- 12 The marking of the equipment or protective system shall include the following :**
Ⓔ II GD Ex d IIC Gb T6 (Ta -40°C to +65°C) Ex tb IIC T85°C Db IP66
- This certificate may only be reproduced in its entirety, without any change, schedule included

Baseefa Customer Reference No. 5989

Project File No. 08/0201

This certificate is granted subject to the general terms and conditions of Baseefa. It does not necessarily indicate that the equipment may be used in particular industries or circumstances.

Baseefa
Rockhead Business Park, Staden Lane,
Buxton, Derbyshire SK17 9RZ
Telephone +44 (0) 1298 766500 Fax +44 (0) 1298 766801
e-mail info@baseefa.com web site www.baseefa.com
Baseefa is a trading name of Baseefa Ltd
Registered in England No. 4305578. Registered address as above.

DTBewley
RP DISCLAIR
R S SINCLAIR
DIRECTOR
On behalf of
Baseefa

ATEX for Sensor

Certificate Number
Baseefa08ATEX0316X



Issued 9 March 2009
Page 1 of 2

EC - TYPE EXAMINATION CERTIFICATE

Equipment or Protective System Intended for use in Potentially Explosive Atmospheres
Directive 94/9/EC

- 1
- 2
- 3 EC - Type Examination Certificate Number: **Baseefa08ATEX0316X**
- 4 Equipment or Protective System: **A Type XCD Gas Sensor Head**
- 5 Manufacturer: **Honeywell Analytics Inc.**
- 6 Address: **405 Barclay Boulevard, Lincolnshire, IL 60069, USA.**
- 7 This equipment or protective system and any acceptable variation thereto is specified in the schedule to this certificate and the documents therein referred to.
- 8 Baseefa, Notified Body number 1180, in accordance with Article 9 of the Council Directive 94/9/EC of 23 March 1994, certifies that this equipment or protective system has been found to comply with the Essential Health and Safety Requirements relating to the design and construction of equipment and protective systems intended for use in potentially explosive atmospheres given in Annex II to the Directive.
- The examination and test results are recorded in confidential Report No. **GB/BAS/ExTR08.0220/00**
- 9 Compliance with the Essential Health and Safety Requirements has been assured by compliance with:
IEC 60079-0: 2007 EN 60079-1: 2007 EN 61241-1: 2004
- except in respect of those requirements listed at item 18 of the Schedule.
- 10 If the sign "X" is placed after the certificate number, it indicates that the equipment or protective system is subject to special conditions for safe use specified in the schedule to this certificate.
- 11 This EC - TYPE EXAMINATION CERTIFICATE relates only to the design and construction of the specified equipment or protective system. Further requirements of the Directive apply to the manufacturing process and supply of this equipment or protective system. These are not covered by this certificate.
- 12 The marking of the equipment or protective system shall include the following :
Ⓔ II 2 GD Ex d IIC T6 (Ta -40°C to +65°C) Gb Ex tb IIIC T85°C Db IP6X A21
- This certificate may only be reproduced in its entirety, without any change, schedule included.

Baseefa Customer Reference No. 5989

Project File No. 08/0261

This certificate is granted subject to the general terms and conditions of Baseefa. It does not necessarily indicate that the equipment may be used in particular industries or circumstances.

Baseefa

Rockhead Business Park, Staden Lane,
Buxton, Derbyshire SK17 9RZ
Telephone +44 (0) 1298 786600 Fax +44 (0) 1298 786801
e-mail info@baseefa.com web site www.baseefa.com
Baseefa is a trading name of Baseefa Ltd
Registered in England No. 4305578. Registered address as above

R S SINCLAIR
DIRECTOR
On behalf of
Baseefa

18.4 International IEC

IEC Ex for Transmitter

		<h2 style="margin: 0;">IECEX Certificate of Conformity</h2>	
<p>INTERNATIONAL ELECTROTECHNICAL COMMISSION IEC Certification Scheme for Explosive Atmospheres <small>for rules and details of the IECEx Scheme visit www.iecex.com</small></p>			
Certificate No.:	IECEX BAS 08.0072	Issue No.: 1	Certificate history: Issue No. 1 (2009-12-08) Issue No. 0 (2008-11-10)
Status:	Current		
Date of Issue:	2009-12-08	Page 1 of 4	
Applicant:	Honeywell Analytics 405 Barclay Boulevard Lincolnshire Illinois 60069 United States of America		
Electrical Apparatus:	A Type XCD Transmitter		
<i>Optional accessory:</i>			
Type of Protection:	Flameproof		
Marking:	Ex d IIC Gb T6 (Ta -40°C to +65°C) Ex tb IIC T85°C Db IP66		
Approved for issue on behalf of the IECEx Certification Body:	R S Sinclair		
Position:	Managing Director		
Signature: <i>(for printed version)</i>	_____		
Date:	_____		
1. This certificate and schedule may only be reproduced in full. 2. This certificate is not transferable and remains the property of the issuing body. 3. The Status and authenticity of this certificate may be verified by visiting the Official IECEx Website.			
Certificate issued by: <div style="display: flex; justify-content: space-between; align-items: center; margin-top: 10px;"> <div style="text-align: center;"> <p>Baseefa Rockhead Business Park Staden Lane Buxton Derbyshire SK17 9RZ United Kingdom</p> </div> <div style="text-align: center;">  </div> </div>			

IEC Ex for Sensor



IECEX Certificate of Conformity

INTERNATIONAL ELECTROTECHNICAL COMMISSION
IEC Certification Scheme for Explosive Atmospheres
for rules and details of the IECEx Scheme visit www.iecex.com

Certificate No.:	IECEX BAS 08.0104X	issue No.:	0
Status:	Current		
Date of Issue:	2009-03-09	Page 1 of 3	
Applicant:	Honeywell Analytics 405 Barclay Boulevard Lincolnshire Illinois 60069 United States of America		
Electrical Apparatus:	A Type XCD Gas Sensor Head		
Optional accessory:			
Type of Protection:	Flameproof and Dust		
Marking:	Ex d IIC T6 (Ta -40°C to +65°C) Gb Ex tb IIIC T85°C Db IP6X A21		
Approved for issue on behalf of the IECEx Certification Body:	R S Sinclair		
Position:	Managing Director		
Signature: <i>(for printed version)</i>			
Date:	<u>10-3-09</u>		

1. This certificate and schedule may only be reproduced in full.
 2. This certificate is not transferable and remains the property of the issuing body.
 3. The Status and authenticity of this certificate may be verified by visiting the [Official IECEx Website](http://www.iecex.com).

Certificate issued by:

Baseefa
 Rockhead Business Park
 Staden Lane
 Buxton
 Derbyshire
 SK17 9RZ
 United Kingdom



18.5 Sensepoint XCD ATEX Name Plate

3001EA041

SHT. 1

THIS DOCUMENT HAS BEEN GENERATED USING
ADOBE ILLUSTRATOR AND MUST ONLY BE UPDATED BY A.I.

THIS ITEM FORMS PART OF A CERTIFIED PRODUCT
NO MODIFICATION PERMITTED WITHOUT
REFERENCE TO CERTIFICATION DEPARTMENT

NOTES

- This is an ATEX schedule drawing and can only be changed after approval is given by the certifying body
- Product name format:
Honeywell Sensepoint XCD XXX
XXX
Blank - Sensepoint XCD for use with Sensepoint XCD socket and sensor.
E - Sensepoint XCD RTD for use with mA input sensors such as Sensepoint Toxic.
RFD - Sensepoint XCD RFD for use with mV input sensors such as Sensepoint Flammable
- Serial no. format
S/N: S1PPYYWNNN
S - Supplier Code
1 - Issue State
PP - Part Code
YY - Year of MFG
W - Week of MFG
NN - Sequence number
- Etching Depth : 0.1 mm

THIS DRAWING IS CONFIDENTIAL. IT IS THE PROPERTY OF HONEYWELL ANALYTICS LTD AND MUST NOT BE REPRODUCED EITHER WHOLLY OR PARTLY. ALL RIGHTS IN RESPECT OF PATENTS, DESIGNS AND COPYRIGHT ARE RESERVED.

FINISH		MATERIAL		SCALE		DRAWING TITLE	
		JIS G4304: SUS 316 Minimum Thickness: 0.5mm		NONE		Sensepoint XCD ATEX Name Plate	
2	18NOV/08	1	30SEP/08	A	ISSUE		
	ADD NOTES		ADD. Cert. IFS6	B	DATE		
	J.Y.JIN		J.Y.JIN	C	16MAY/08		
			ADD. Cert. IFS6	D	17JUN/08		
			ADD. Cert. IFS6	E	16MAY/08		
			ADD. Cert. IFS6	F	16MAY/08		
			ADD. Cert. IFS6	G	16MAY/08		
			ADD. Cert. IFS6	H	16MAY/08		
			ADD. Cert. IFS6	I	16MAY/08		
			ADD. Cert. IFS6	J	16MAY/08		
			ADD. Cert. IFS6	K	16MAY/08		
			ADD. Cert. IFS6	L	16MAY/08		
			ADD. Cert. IFS6	M	16MAY/08		
			ADD. Cert. IFS6	N	16MAY/08		
			ADD. Cert. IFS6	O	16MAY/08		
			ADD. Cert. IFS6	P	16MAY/08		
			ADD. Cert. IFS6	Q	16MAY/08		
			ADD. Cert. IFS6	R	16MAY/08		
			ADD. Cert. IFS6	S	16MAY/08		
			ADD. Cert. IFS6	T	16MAY/08		
			ADD. Cert. IFS6	U	16MAY/08		
			ADD. Cert. IFS6	V	16MAY/08		
			ADD. Cert. IFS6	W	16MAY/08		
			ADD. Cert. IFS6	X	16MAY/08		
			ADD. Cert. IFS6	Y	16MAY/08		
			ADD. Cert. IFS6	Z	16MAY/08		
			ADD. Cert. IFS6	AA	16MAY/08		
			ADD. Cert. IFS6	AB	16MAY/08		
			ADD. Cert. IFS6	AC	16MAY/08		
			ADD. Cert. IFS6	AD	16MAY/08		
			ADD. Cert. IFS6	AE	16MAY/08		
			ADD. Cert. IFS6	AF	16MAY/08		
			ADD. Cert. IFS6	AG	16MAY/08		
			ADD. Cert. IFS6	AH	16MAY/08		
			ADD. Cert. IFS6	AI	16MAY/08		
			ADD. Cert. IFS6	AJ	16MAY/08		
			ADD. Cert. IFS6	AK	16MAY/08		
			ADD. Cert. IFS6	AL	16MAY/08		
			ADD. Cert. IFS6	AM	16MAY/08		
			ADD. Cert. IFS6	AN	16MAY/08		
			ADD. Cert. IFS6	AO	16MAY/08		
			ADD. Cert. IFS6	AP	16MAY/08		
			ADD. Cert. IFS6	AQ	16MAY/08		
			ADD. Cert. IFS6	AR	16MAY/08		
			ADD. Cert. IFS6	AS	16MAY/08		
			ADD. Cert. IFS6	AT	16MAY/08		
			ADD. Cert. IFS6	AU	16MAY/08		
			ADD. Cert. IFS6	AV	16MAY/08		
			ADD. Cert. IFS6	AW	16MAY/08		
			ADD. Cert. IFS6	AX	16MAY/08		
			ADD. Cert. IFS6	AY	16MAY/08		
			ADD. Cert. IFS6	AZ	16MAY/08		
			ADD. Cert. IFS6	BA	16MAY/08		
			ADD. Cert. IFS6	BB	16MAY/08		
			ADD. Cert. IFS6	BC	16MAY/08		
			ADD. Cert. IFS6	BD	16MAY/08		
			ADD. Cert. IFS6	BE	16MAY/08		
			ADD. Cert. IFS6	BF	16MAY/08		
			ADD. Cert. IFS6	BG	16MAY/08		
			ADD. Cert. IFS6	BH	16MAY/08		
			ADD. Cert. IFS6	BI	16MAY/08		
			ADD. Cert. IFS6	BJ	16MAY/08		
			ADD. Cert. IFS6	BK	16MAY/08		
			ADD. Cert. IFS6	BL	16MAY/08		
			ADD. Cert. IFS6	BM	16MAY/08		
			ADD. Cert. IFS6	BN	16MAY/08		
			ADD. Cert. IFS6	BO	16MAY/08		
			ADD. Cert. IFS6	BP	16MAY/08		
			ADD. Cert. IFS6	BQ	16MAY/08		
			ADD. Cert. IFS6	BR	16MAY/08		
			ADD. Cert. IFS6	BS	16MAY/08		
			ADD. Cert. IFS6	BT	16MAY/08		
			ADD. Cert. IFS6	BU	16MAY/08		
			ADD. Cert. IFS6	BV	16MAY/08		
			ADD. Cert. IFS6	BW	16MAY/08		
			ADD. Cert. IFS6	BX	16MAY/08		
			ADD. Cert. IFS6	BY	16MAY/08		
			ADD. Cert. IFS6	BZ	16MAY/08		
			ADD. Cert. IFS6	CA	16MAY/08		
			ADD. Cert. IFS6	CB	16MAY/08		
			ADD. Cert. IFS6	CC	16MAY/08		
			ADD. Cert. IFS6	CD	16MAY/08		
			ADD. Cert. IFS6	CE	16MAY/08		
			ADD. Cert. IFS6	CF	16MAY/08		
			ADD. Cert. IFS6	CG	16MAY/08		
			ADD. Cert. IFS6	CH	16MAY/08		
			ADD. Cert. IFS6	CI	16MAY/08		
			ADD. Cert. IFS6	CJ	16MAY/08		
			ADD. Cert. IFS6	CK	16MAY/08		
			ADD. Cert. IFS6	CL	16MAY/08		
			ADD. Cert. IFS6	CM	16MAY/08		
			ADD. Cert. IFS6	CN	16MAY/08		
			ADD. Cert. IFS6	CO	16MAY/08		
			ADD. Cert. IFS6	CP	16MAY/08		
			ADD. Cert. IFS6	CQ	16MAY/08		
			ADD. Cert. IFS6	CR	16MAY/08		
			ADD. Cert. IFS6	CS	16MAY/08		
			ADD. Cert. IFS6	CT	16MAY/08		
			ADD. Cert. IFS6	CU	16MAY/08		
			ADD. Cert. IFS6	CV	16MAY/08		
			ADD. Cert. IFS6	CW	16MAY/08		
			ADD. Cert. IFS6	CX	16MAY/08		
			ADD. Cert. IFS6	CY	16MAY/08		
			ADD. Cert. IFS6	CZ	16MAY/08		
			ADD. Cert. IFS6	DA	16MAY/08		
			ADD. Cert. IFS6	DB	16MAY/08		
			ADD. Cert. IFS6	DC	16MAY/08		
			ADD. Cert. IFS6	DD	16MAY/08		
			ADD. Cert. IFS6	DE	16MAY/08		
			ADD. Cert. IFS6	DF	16MAY/08		
			ADD. Cert. IFS6	DG	16MAY/08		
			ADD. Cert. IFS6	DH	16MAY/08		
			ADD. Cert. IFS6	DI	16MAY/08		
			ADD. Cert. IFS6	DJ	16MAY/08		
			ADD. Cert. IFS6	DK	16MAY/08		
			ADD. Cert. IFS6	DL	16MAY/08		
			ADD. Cert. IFS6	DM	16MAY/08		
			ADD. Cert. IFS6	DN	16MAY/08		
			ADD. Cert. IFS6	DO	16MAY/08		
			ADD. Cert. IFS6	DP	16MAY/08		
			ADD. Cert. IFS6	DQ	16MAY/08		
			ADD. Cert. IFS6	DR	16MAY/08		
			ADD. Cert. IFS6	DS	16MAY/08		
			ADD. Cert. IFS6	DT	16MAY/08		
			ADD. Cert. IFS6	DU	16MAY/08		
			ADD. Cert. IFS6	DV	16MAY/08		
			ADD. Cert. IFS6	DW	16MAY/08		
			ADD. Cert. IFS6	DX	16MAY/08		
			ADD. Cert. IFS6	DY	16MAY/08		
			ADD. Cert. IFS6	DZ	16MAY/08		
			ADD. Cert. IFS6	EA	16MAY/08		
			ADD. Cert. IFS6	EB	16MAY/08		
			ADD. Cert. IFS6	EC	16MAY/08		
			ADD. Cert. IFS6	ED	16MAY/08		
			ADD. Cert. IFS6	EE	16MAY/08		
			ADD. Cert. IFS6	EF	16MAY/08		
			ADD. Cert. IFS6	EG	16MAY/08		
			ADD. Cert. IFS6	EH	16MAY/08		
			ADD. Cert. IFS6	EI	16MAY/08		
			ADD. Cert. IFS6	EJ	16MAY/08		
			ADD. Cert. IFS6	EK	16MAY/08		
			ADD. Cert. IFS6	EL	16MAY/08		
			ADD. Cert. IFS6	EM	16MAY/08		
			ADD. Cert. IFS6	EN	16MAY/08		
			ADD. Cert. IFS6	EO	16MAY/08		
			ADD. Cert. IFS6	EP	16MAY/08		
			ADD. Cert. IFS6	EQ	16MAY/08		
			ADD. Cert. IFS6	ER	16MAY/08		
			ADD. Cert. IFS6	ES	16MAY/08		
			ADD. Cert. IFS6	ET	16MAY/08		
			ADD. Cert. IFS6	EU	16MAY/08		
			ADD. Cert. IFS6	EV	16MAY/08		
			ADD. Cert. IFS6	EW	16MAY/08		
			ADD. Cert. IFS6	EX	16MAY/08		
			ADD. Cert. IFS6	EY	16MAY/08		
			ADD. Cert. IFS6	EZ	16MAY/08		
			ADD. Cert. IFS6	FA	16MAY/08		
			ADD. Cert. IFS6	FB	16MAY/08		
			ADD. Cert. IFS6	FC	16MAY/08		
			ADD. Cert. IFS6	FD	16MAY/08		
			ADD. Cert. IFS6	FE	16MAY/08		
			ADD. Cert. IFS6	FF	16MAY/08		
			ADD. Cert. IFS6	FG	16MAY/08		
			ADD. Cert. IFS6	FH	16MAY/08		
			ADD. Cert. IFS6	FI	16MAY/08		
			ADD. Cert. IFS6	FJ	16MAY/08		
			ADD. Cert. IFS6	FK	16MAY/08		
			ADD. Cert. IFS6	FL	16MAY/08		
			ADD. Cert. IFS6	FM	16MAY/08		
			ADD. Cert. IFS6	FN	16MAY/08		
			ADD. Cert. IFS6	FO	16MAY/08		
			ADD. Cert. IFS6	FP	16MAY/08		
			ADD. Cert. IFS6	FQ	16MAY/08		
			ADD. Cert. IFS6	FR	16MAY/08		
			ADD. Cert. IFS6	FS	16MAY/08		
			ADD. Cert. IFS6	FT	16MAY/08		
			ADD. Cert. IFS6	FU	16MAY/08		
			ADD. Cert. IFS6	FV	16MAY/08		
			ADD. Cert. IFS6	FW	16MAY/08		
			ADD. Cert. IFS6	FX	16MAY/08		
			ADD. Cert. IFS6	FY	16MAY/08		

19 Cross Interference and Cross Calibration

19.1 Cross Calibration Flammable Gas Detector

For greater accuracy, a catalytic gas detector should be calibrated using a certified gas/air mixture equal to 50% LEL of the actual target gas intended to be monitored.

However, it is not always practical to obtain every detectable type of hydrocarbon gas in a calibration-ready, certified and verifiable form. Therefore, it is possible to carry out a “cross calibration” using another hydrocarbon gas/air mixture.

When the Sensepoint XCD Combustible LEL sensor is to be calibrated with a gas which is different to the gas or vapour to be detected, the following cross calibration procedure may be followed:

Caution: Where the user calibrates any sensor using a different gas, responsibility for identifying and recording calibration rests with the user. Refer to the local regulations where appropriate.

Notes:

1. Table 14 lists a selection of hydrocarbon compounds and states a reference figure or “Star Rating” according to the reaction they produce in relation to other hydrocarbons.
2. An eight star (8*) gas produces the highest output, while a one star (1*) gas produces the lowest output.

No.	Gas	Star Rating
1	Acetone	4*
2	Ammonia	7*
3	Benzene	3*
4	Butanone	3*
5	Butane	4*
6	Butyl acetate	1*
7	Butyl acrylate	1*
8	Cyclohexane	3*
9	Cyclohexanone	<1*
10	Diethyl ether	4*
11	Ethane	6*
12	Ethanol	5*
13	Ethyl acetate	3*
14	Ethylene	5*
15	Heptane	3*
16	Hexane	3*
17	Hydrogen	6*
18	Methane	6*
19	Methanol	5*
20	MIBK	3*
21	Octane	3*

22	Pentane	3*
23	Propane	5*
24	Propan-2-ol	4*
25	Styrene	2*
26	Tetra hydrofuran	4*
27	Toluene	3*
28	Triethylamine	3*
29	Xylene	2*

Table 14 . Star Rating of Gases

To cross calibrate the Sensepoint XCD flammable gas detector:

- (1) Obtain the star rating for both the calibration test gas and the gas to be detected from Table 14
- (2) These values may then be used in Table 15 to obtain the required calibration span setting when a 50% LEL test gas is applied to the detector.

*Rating of Calibration Gas	*Rating of Gas to be Detected							
	8*	7*	6*	5*	4*	3*	2*	1*
8*	50	62	76	95	-	-	-	-
7*	40	50	61	76	-	-	-	-
6*	33	41	50	62	78	-	-	-
5*	26	33	40	50	63	79	-	-
4*	-	26	32	40	50	63	80	-
3*	-	-	26	32	40	50	64	81
2*	-	-	-	25	31	39	50	64
1*	-	-	-	-	25	31	39	50

Note: These settings must only be used with a calibration gas concentration of 50% LEL.

Table 15. Calibration span setting

- (3) If a sensor is to be used to detect a gas other than that for which it was calibrated and there is no intention to use an equivalent calibration gas to re-calibrate the sensor, then the required correction factor may be obtained from Table 16.

The reading shown on the gas detector controller or transmitter display should be multiplied by this number in order to obtain a more accurate gas concentration result.

Sensor calibrated to detect	Sensor used to detect							
	8*	7*	6*	5*	4*	3*	2*	1*
8*	1.00	1.24	1.52	1.89	2.37	2.98	3.78	4.83
7*	0.81	1.00	1.23	1.53	1.92	2.40	3.05	3.90
6*	0.66	0.81	1.00	1.24	1.56	1.96	2.49	3.17
5*	0.53	0.66	0.80	1.00	1.25	1.58	2.00	2.55
4*	0.42	0.52	0.54	0.80	1.00	1.26	1.60	2.03
3*	0.34	0.42	0.51	0.64	0.80	1.00	1.27	1.62
2*	0.26	0.33	0.40	0.50	0.63	0.79	1.00	1.28
1*	0.21	0.26	0.32	0.39	0.49	0.62	0.78	1.00

Table 16. Correction factors

Notes:

1. *Since catalytic sensors require oxygen for correct operation, a mixture of gas in air should always be used for calibration purposes.*
2. *Assuming average performance of the sensor, the sensitivity information in Tables 14 To 16 is normally accurate to + or - 30%.*

Working Example:

If the target gas to be detected is 0-100%LEL Ethylene and the only calibration gas available to re-calibrate the sensor is Methane (at 50% LEL concentration), the procedure is as follows:

- (1) Look up the star rating for each gas in Table 14:

Gas No. 14, Ethylene = 5*

Gas no. 18, Methane = 6*

- (2) Then, look up the span settings for a 50% LEL calibration gas in Table 15 by selecting the row of figures next to the 6* in the "calibration gas" column. Select the figure in the 5* column of the "gas to be detected" section. The figure is 62.

- (3) This means that during re-calibration, the span gas setting on the gas detector transmitter or controller should be set to 62% LEL to give an accurate measuring scale for 0-100%LEL Ethylene, when using 50% LEL Methane as the calibration gas.

Section 19.1 is used for Sensepoint XCD Catalytic Sensor only, please refer to Sensepoint Technical Manual for using Sensepoint flammable gas sensors.

Please contact your local Honeywell Analytics sales or service distributor, or regional office should further clarification or additional information be required.

19.2 Meter Multiplication Factors for Sensepoint XCD-IR Propane

It is possible to apply a linear cross reference factor to the output of a sensor characterized for propane and achieve the results shown in the graph below.

Reasonable accuracy is maintained to at least the 50% LEL equivalent values of the cross-referred gasses.

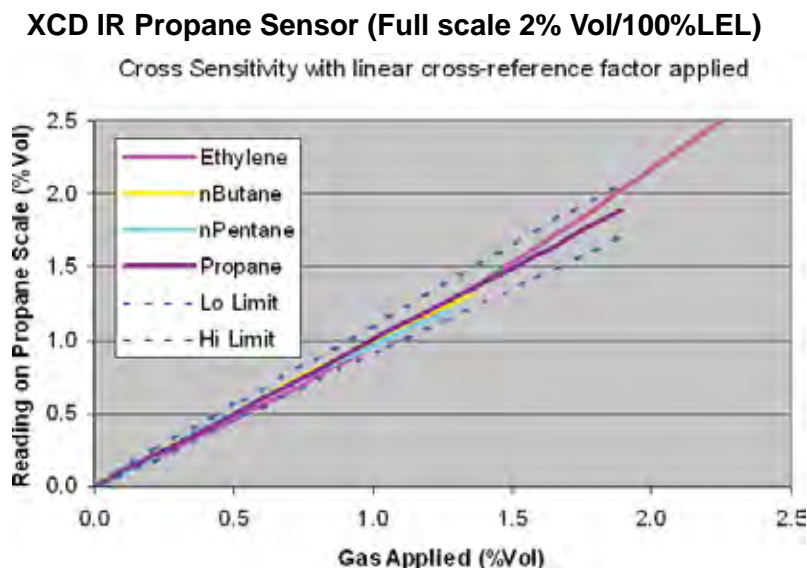

Diagram 18. Sensepoint XCD-IR (Propane) Sensor with linear cross-reference factor applied

Use the following multiplying factors to cross-refer to the propane reading:

Gas	Multiplication Factor
Ethylene	3.43
nButane	0.97
nPentane	0.89

Table 17. Multiplying Factors

Caution: These factors only apply to gas concentrations expressed in % Volume terms. When using a linear cross reference factor the temperature compensation is based upon propane, and there may be errors at temperatures away from the calibration temperature.

NOTE

Honeywell Analytics recommends that users verify the accuracy of their instruments using test gasses wherever possible. Cross-referred measurements should be used as a guide only, not as absolute values.

Find out more

www.honeywellanalytics.com

Contact Honeywell Analytics:**Europe, Middle East, Africa, India**

Life Safety Distribution AG
Weiherallee 11a
CH-8610 Uster
Switzerland
Tel: +41 (0)44 943 4300
Fax: +41 (0)44 943 4398
gasdetection@honeywell.com

Americas

Honeywell Analytics Inc.
405 Barclay Blvd.
Lincolnshire, IL 60069
USA
Tel: +1 847 955 8200
Toll free: +1 800 538 0363
Fax: +1 847 955 8210
detectgas@honeywell.com

Asia Pacific

Honeywell Analytics Asia Pacific
#508, Kolon Science Valley (I)
187-10 Guro-Dong, Guro-Gu
Seoul, 152-050
Korea
Tel: +82 (0)2 6909 0300
Fax: +82 (0)2 2025 0329
analytics.ap@honeywell.com

Technical Services

EMEA: HAexpert@honeywell.com
US: ha.us.service@honeywell.com
AP: ha.ap.service@honeywell.com

www.honeywell.com

Please Note:

While every effort has been made to ensure accuracy in this publication, no responsibility can be accepted for errors or omissions. Data may change, as well as legislation, and you are strongly advised to obtain copies of the most recently issued regulations, standards, and guidelines. This publication is not intended to form the basis of a contract.

Issue 1 03/2010
3001M5023
SPXCDHMRFEN
MAN0894_EMEA
© 2010 Honeywell Analytics

The Honeywell logo is displayed in a bold, red, sans-serif font.